

1. $A_v = \frac{v_o}{v_i} = ?$

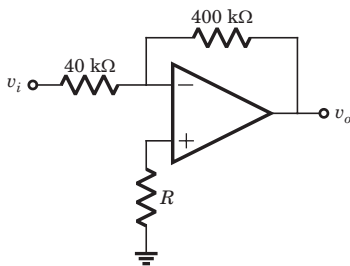

Fig. P3.5.1

- (A) -10 (B) 10
(C) -11 (D) 11

2. $A_v = \frac{v_o}{v_i} = ?$

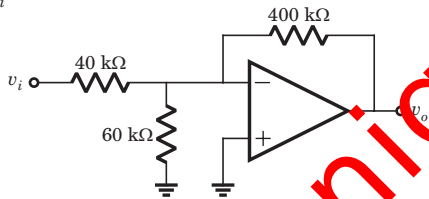

Fig. P3.5.2

- (A) -10 (B) 10
(C) 13.46 (D) -13.46

3. The input to the circuit in fig. P3.5.3 is $v_i = 2 \sin \omega t$ mV. The current i_o is

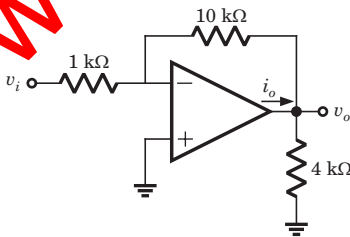

Fig. P3.5.3

- (A) $-2 \sin \omega t \mu A$ (B) $-7 \sin \omega t \mu A$
(C) $-5 \sin \omega t \mu A$ (D) 0

4. In circuit shown in fig. P3.5.4, the input voltage v_i is 0.2 V. The output voltage v_o is

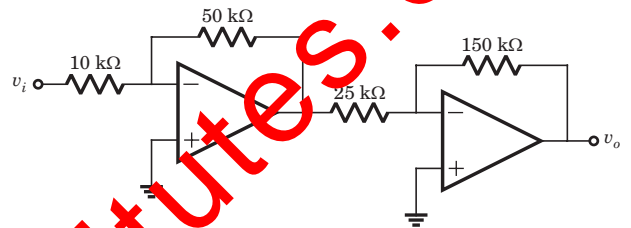

Fig. P3.5.4

- (A) 0 V (B) -6 V
(C) 8 V (D) -8 V

5. For the circuit shown in fig. P3.5.5 gain is $A_v = v_o/v_i = -10$. The value of R is

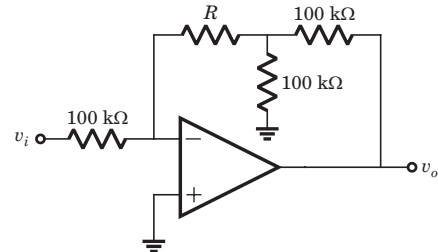

Fig. P3.5.5

- (A) 600 kΩ (B) 450 kΩ
(C) 4.5 MΩ (D) 6 MΩ

6. For the op-amp circuit shown in fig. P3.5.6 the voltage gain $A_v = v_o/v_i$ is

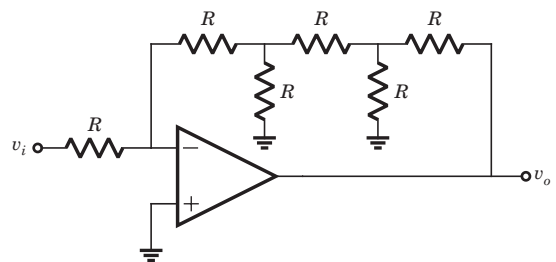

Fig. P3.5.6

- (A) -8
- (B) 8
- (C) -10
- (D) 10

7. For the op-amp shown in fig. P3.5.7 open loop differential gain is $A_{od} = 10^3$. The output voltage v_o for $v_i = 2 \text{ V}$ is

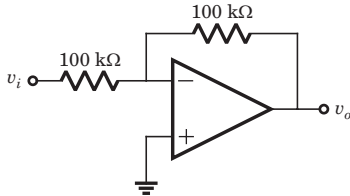

Fig. P3.5.7

- (A) -1.996
- (B) -1.998
- (C) -2.004
- (D) -2.006

8. The op-amp of fig. P3.5.8 has a very poor open-loop voltage gain of 45 but is otherwise ideal. The closed-loop gain of amplifier is

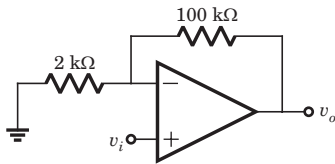

Fig. P3.5.8

- (A) 20
- (B) 4.5
- (C) 4
- (D) 5

9. For the circuit shown in fig. P3.5.9 the input voltage v_i is 1.5 V. The current i_o is

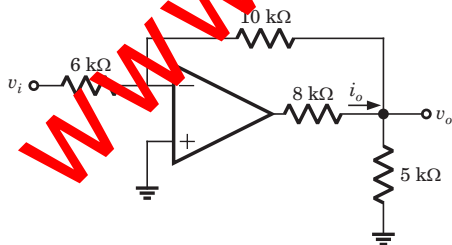

Fig. P3.5.9

- (A) -1.5 mA
- (B) 1.5 mA
- (C) -0.75 mA
- (D) 0.75 mA

10. In the circuit of fig. P3.5.10 the output voltage v_o is

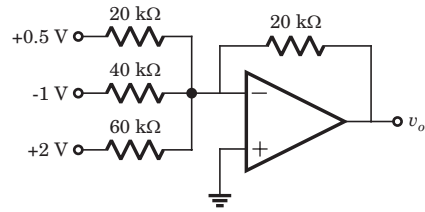

Fig. P3.5.10

- (A) 2.67 V
- (B) -2.67 V
- (C) -6.67 V
- (D) 6.67 V

11. In the circuit of fig. P3.5.11 the voltage v_{i1} is $(1 + 2 \sin \omega t) \text{ mV}$ and $v_{i2} = -10 \text{ mV}$. The output voltage v_o is

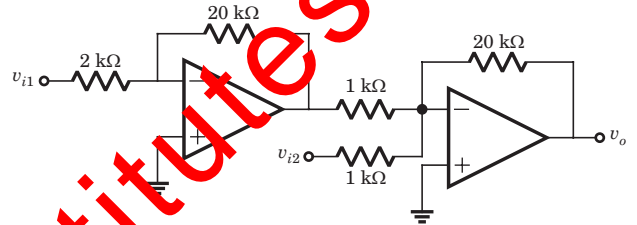

Fig. P3.5.11

- (A) $-0.4(1 + \sin \omega t) \text{ mV}$
- (B) $0.4(1 + \sin \omega t) \text{ mV}$
- (C) $0.4(1 + 2 \sin \omega t) \text{ mV}$
- (D) $-0.4(1 + 2 \sin \omega t) \text{ mV}$

12. For the circuit in fig. P3.5.12 the output voltage is $v_o = 2.5 \text{ V}$ in response to input voltage $v_i = 5 \text{ V}$. The finite open-loop differential gain of the op-amp is

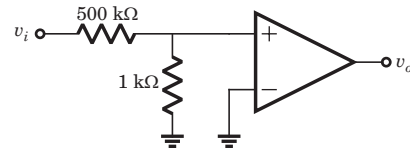

Fig. P3.5.12

- (A) 5×10^4
- (B) 250.5
- (C) 2×10^4
- (D) 501

13. $v_o = ?$

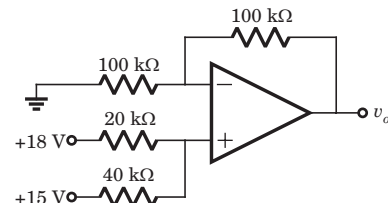

Fig. P3.5.13

- (A) 34 V
- (B) -17 V
- (C) 32 V
- (D) -32 V

14. $v_o = ?$

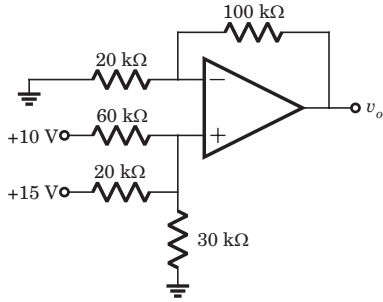

Fig. P3.5.14

- (A) -5.5 V
- (B) 4.58 V
- (C) 5.5 V
- (D) -4.58 V

15. $A_v = \frac{v_o}{v_i} = ?$

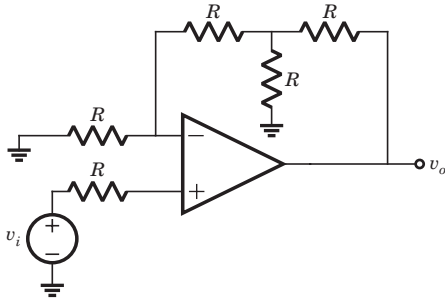

Fig. P3.5.15

- (A) 5
- (B) -5
- (C) 6
- (D) -6

Statement for Q.16-17:

The circuit is as shown in fig. P3.5.16-17.

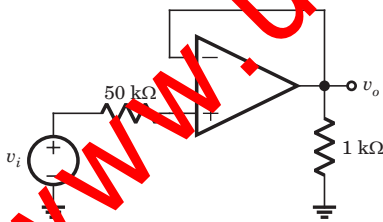

Fig. P3.5.16-17

16. The ideal closed-loop voltage gain is

- (A) 1
- (B) -1
- (C) ∞
- (D) 50

17. If open-loop gain is $A_{od} = 999$, then closed-loop gain is

- (A) -0.999
- (B) 0.999
- (C) 1.001
- (D) -1.001

18. For the circuit shown in fig. P3.5.18 the true relation is

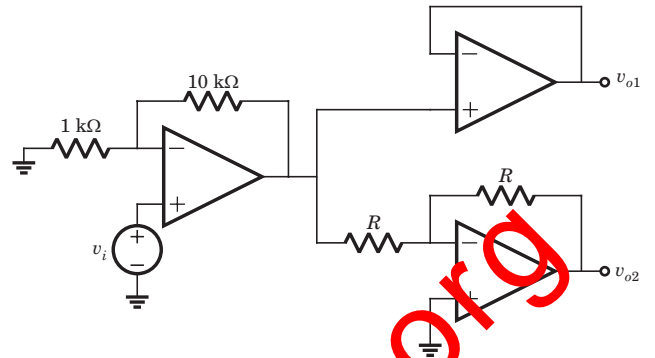

Fig. P3.5.18

- (A) $v_{o1} = v_{o2}$
- (B) $v_{o1} = -v_{o2}$
- (C) $v_o = 2v_{o2}$
- (D) $2v_{o1} = v_{o2}$

19. $v_o = ?$

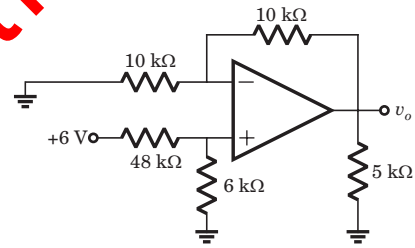

Fig. P3.5.19

- (A) $\frac{4}{3}$ V
- (B) $-\frac{2}{3}$ V
- (C) $\frac{2}{3}$ V
- (D) $-\frac{4}{3}$ V

20. $v_o = ?$

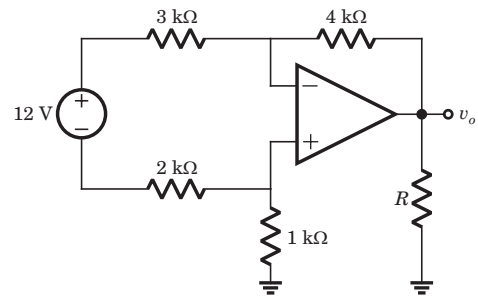

Fig. P3.5.20

- (A) -12 V
- (B) 12 V
- (C) -18 V
- (D) 18 V

21. $v_o = ?$

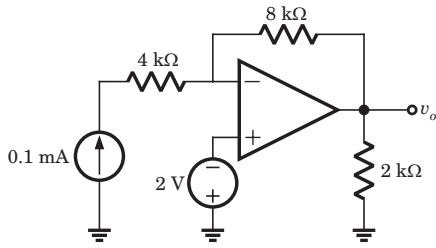

Fig. P3.5.21

- (A) -30V (B) 18V
(C) -18V (D) 28V

22. $v_o = ?$

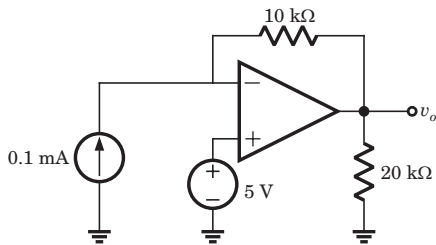

Fig. P3.5.22

- (A) 4 V (B) -4 V
(C) 5 V (D) -5 V

23. $i_o = ?$

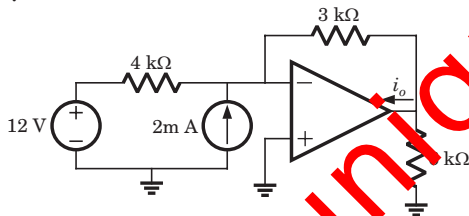

Fig. P3.5.23

- (A) 12 mA (B) 8.5 mA
(C) 6 mA (D) 7.5 mA

24. $v_o = ?$

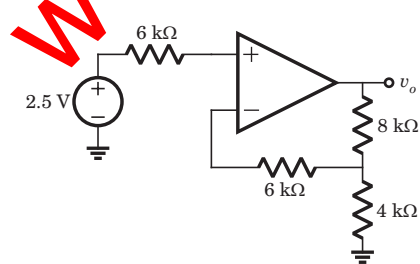

Fig. P3.5.24

- (A) -7.5 V (B) 7.5 V
(C) 8 V (D) -8 V

25. $A_{vd} = \frac{v_o}{(v_1 - v_2)} = ?$

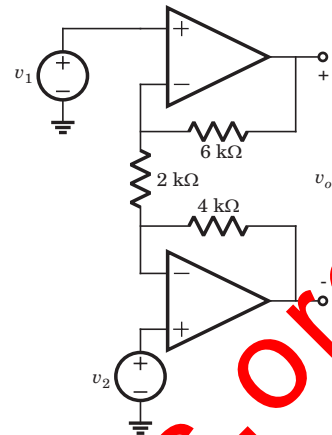

Fig. P3.5.25

- (A) 8 (B) -6
(C) 6 (D) -8

26. $v_o = ?$

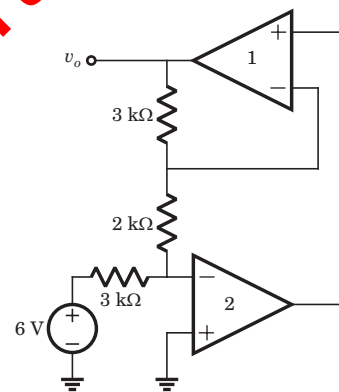

Fig. 3.5.26

- (A) 6 V (B) -6 V
(C) -10 V (D) 10 V

27. $A_v = \frac{v_o}{v_i} = ?$

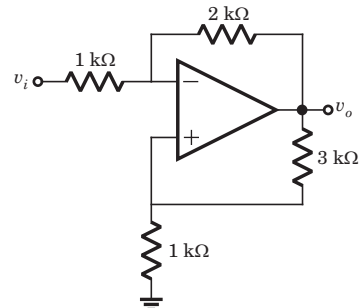

Fig. P3.5.27

- (A) 15.8 (B) -10
(C) -17.4 (D) -8

28. For the circuit shown in fig. P3.5.28 the input resistance is

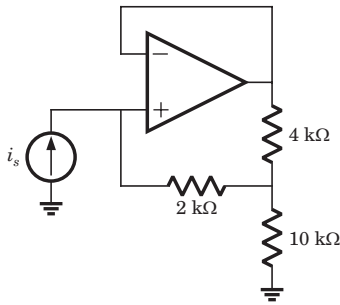

Fig. P3.5.28

- (A) 38 kΩ
- (B) 17 kΩ
- (C) 25 kΩ
- (D) 47 kΩ

29. In the circuit of fig. P3.5.29 the op-amp slew rate is $SR = 0.5 \text{ V}/\mu\text{s}$. If the amplitude of input signal is 0.02 V, then the maximum frequency that may be used is

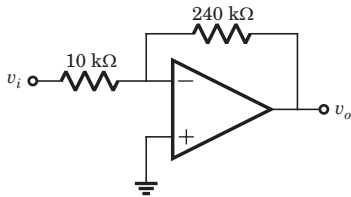

Fig. P3.5.29

- (A) $0.55 \times 10^6 \text{ rad/s}$
- (B) 0.55 rad/s
- (C) $1.1 \times 10^6 \text{ rad/s}$
- (D) 1.1 rad/s

30. In the circuit of fig. P3.5.30 the input offset voltage and input offset current are $V_{io} = 4 \text{ mV}$ and $I_{io} = 150 \text{ nA}$. The total output offset voltage is

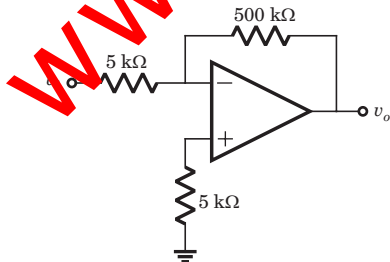

Fig. P3.5.30

- (A) 479 mV
- (B) 234 mV
- (C) 168 mV
- (D) 116 mV

31. $i_o = ?$

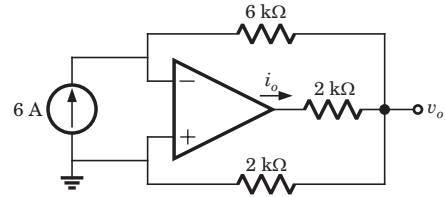

Fig. S3.5.31

- (A) -18 A
- (B) 18 A
- (C) -36 A
- (D) 36 A

Statement for Q.32-33:

Consider the circuit shown below

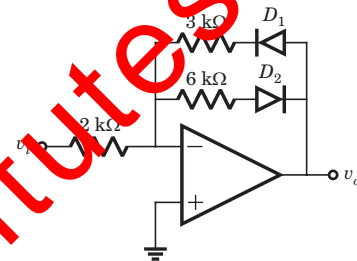

Fig. P3.5.32-33

32. If $v_i = 2 \text{ V}$, then output v_o is

- (A) 4 V
- (B) -4 V
- (C) 3 V
- (D) -3 V

33. If $v_i = -2 \text{ V}$, then output v_o is

- (A) -6 V
- (B) 6 V
- (C) -3 V
- (D) 3 V

34. $v_o(t) = ?$

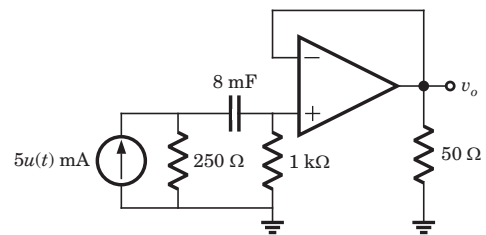

Fig. P3.5.34

- (A) $e^{-\frac{t}{10}} u(t) \text{ V}$
- (B) $-e^{-\frac{t}{10}} u(t) \text{ V}$
- (C) $e^{-\frac{t}{1.6}} u(t) \text{ V}$
- (D) $-e^{-\frac{t}{1.6}} u(t) \text{ V}$

35. The circuit shown in fig. P3.5.35 is at steady state before the switch opens at $t = 0$. The voltage $v_c(t)$ for $t > 0$ is

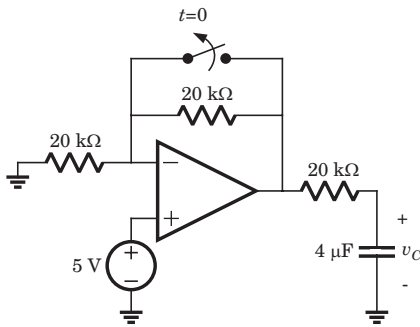

Fig. P3.5.35

- (A) $10 - 5e^{-12.5t}$ V
- (B) $5 + 5e^{-12.5t}$ V
- (C) $5 + 5e^{-\frac{t}{12.5}}$ V
- (D) $10 - 5e^{-\frac{t}{12.5}}$ V

36. The LED in the circuit of fig. P3.5.36 will be on if v_i is

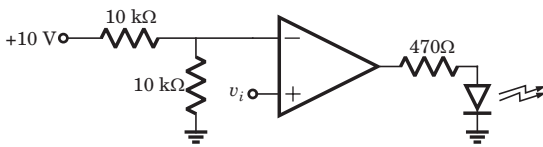

Fig. P3.5.36

- (A) > 10 V
- (B) < 10 V
- (C) > 5 V
- (D) < 5 V

37. In the circuit of fig. P3.5.37 the CMRR of the op-amp is 60 dB. The magnitude of the v_o is

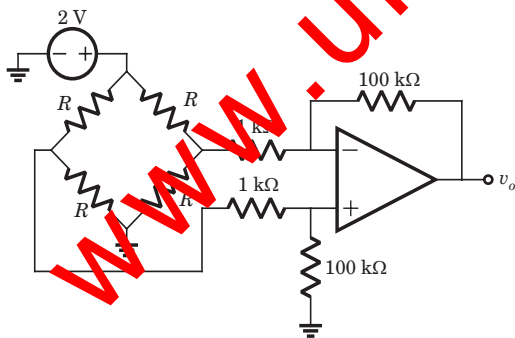

Fig. P3.5.37

- (A) 1 mV
- (B) 100 mV
- (C) 200 mV
- (D) 2 mV

38. The analog multiplier X of fig. P3.5.38 has the characteristics $v_p = v_1 v_2$. The output of this circuit is

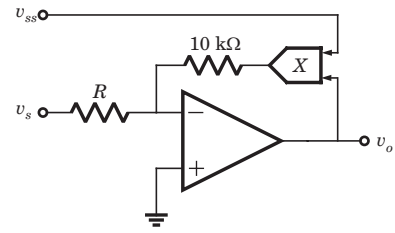

Fig. P3.5.38

- (A) $v_s v_{ss}$
- (B) $-v_s v_{ss}$
- (C) $-\frac{v_s}{v_{ss}}$
- (D) $\frac{v_s}{v_{ss}}$

39. If the input to the ideal comparator shown in fig. P3.5.39 is a sinusoidal signal of 8 V (peak to peak) without any DC component, then the output of the comparator has a duty cycle of

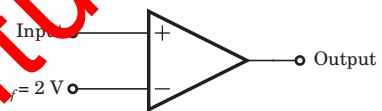

Fig. P3.5.39

- (A) $\frac{1}{2}$
- (B) $\frac{1}{3}$
- (C) $\frac{1}{6}$
- (D) $\frac{1}{12}$

40. In the op-amp circuit given in fig. P3.5.40 the load current i_L is

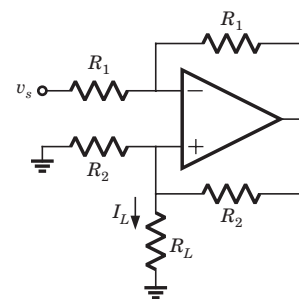

Fig. P3.5.40

- (A) $-\frac{v_s}{R_2}$
- (B) $\frac{v_s}{R_2}$
- (C) $-\frac{v_s}{R_L}$
- (D) $\frac{v_s}{R_L}$

41. In the circuit of fig. P3.5.41 output voltage is $|v_o| = 1$ V for a certain set of ω , R , and C . The $|v_o|$ will be 2 V if

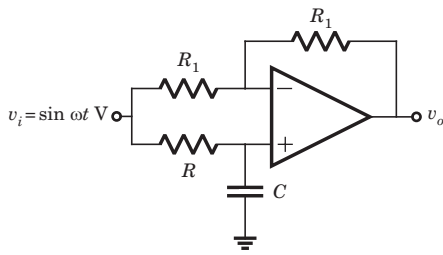

Fig. P3.5.41

- (A) ω is doubled
- (B) ω is halved
- (C) R is doubled
- (D) None of the above

42. In the filter circuit of fig. P3.5.42. the 3 dB cutoff frequency is

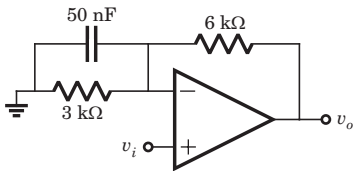

Fig. P3.5.42

- (A) 10 kHz
- (B) 1.59 kHz
- (C) 354 Hz
- (D) 689 Hz

43. The phase shift oscillator of fig. P3.5.43 operate at $f = 80$ kHz. The value of resistance R_F is

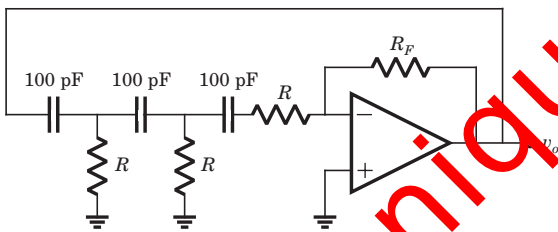

Fig. P3.5.43

- (A) 148 kΩ
- (B) 236 kΩ
- (C) 438 kΩ
- (D) 814 kΩ

44. The value of C required for sinusoidal oscillation of frequency 1 kHz in the circuit of fig. P3.5.44 is

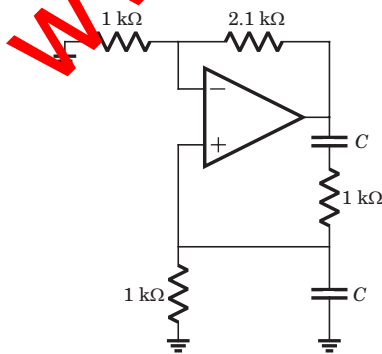

Fig. P3.5.44

- (A) $\frac{1}{2\pi} \mu\text{F}$
- (B) $2\pi \mu\text{F}$
- (C) $\frac{1}{2\pi\sqrt{6}} \mu\text{F}$
- (D) $2\pi\sqrt{6} \mu\text{F}$

45. In the circuit shown in fig. P3.5.45 the op-amp is ideal. If $\beta_F = 60$, then the total current supplied by the 15 V source is

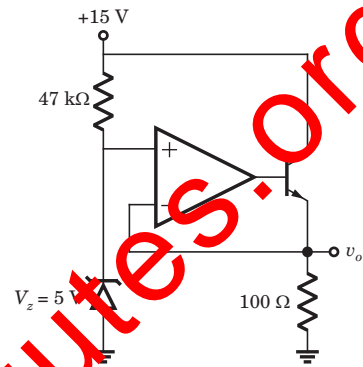

Fig. P3.5.45

- (A) 123.1 mA
- (B) 98.3 mA
- (C) 133.1 mA
- (D) 168 mA

46. In the circuit in fig. P3.5.46 both transistor Q_1 and Q_2 are identical. The output voltage at $T = 300$ K is

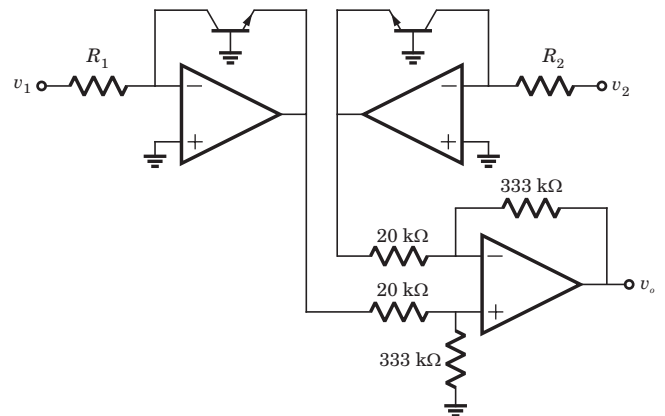

Fig. P3.5.46

- (A) $2 \log_{10} \left(\frac{v_2 R_1}{v_1 R_2} \right)$
- (B) $\log_{10} \left(\frac{v_2 R_1}{v_1 R_2} \right)$
- (C) $2.303 \log_{10} \left(\frac{v_2 R_1}{v_1 R_2} \right)$
- (D) $4.605 \log_{10} \left(\frac{v_2 R_1}{v_1 R_2} \right)$

47. In the op-amp series regulator circuit of fig. P8.3.47 $V_z = 6.2$ V, $V_{BE} = 0.7$ V and $\beta = 60$. The output voltage v_o is

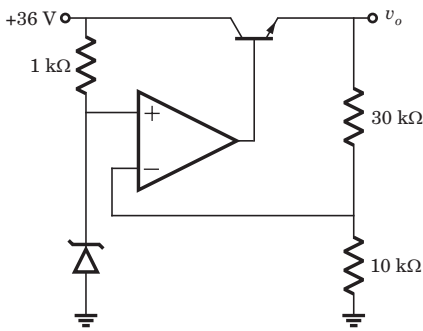

Fig. P3.5.47

- (A) 35.8 V
- (B) 24.8 V
- (C) 29.8 V
- (D) None of the above

Solutions

1. (A) This is inverting amplifier

$$A_v = -\frac{R_F}{R_1} = -\frac{400}{40} = -10$$

2. (A) The noninverting terminal is at ground level. Thus inverting terminal is also at virtual ground. There will not be any current in 60 kΩ.

$$A_v = -\frac{400}{40} = -10$$

3. (B) $v_o = -\frac{10}{1}(2 \sin \omega t) \text{ mV} = -20 \sin \omega t \text{ mV}$

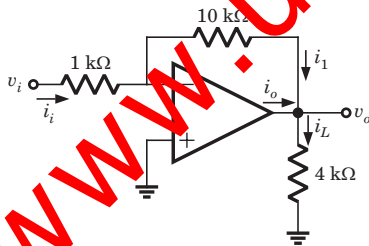

Fig. S3.5.3

$$i_L = \frac{v_o}{4k} = -5 \sin \omega t \mu A$$

$$i_1 = i_i = \frac{2 \sin \omega t}{1k} = 2 \sin \omega t \mu A$$

$$i_o = i_L - i_1 = -5 \sin \omega t - 2 \sin \omega t = -7 \sin \omega t \mu A$$

4. (A) Gain of first stage $A_{v1} = -\frac{50}{10} = -5$

$$\text{Gain of second stage } A_{v2} = -\frac{150}{25} = -6$$

$$\text{Total gain } A_v = A_{v1}A_{v2} = 30, v_o = 30 \times 0.2 = 6 \text{ V}$$

5. (B) Let v_x be the node voltage

$$\frac{v_x}{R} + \frac{v_x}{100} + \frac{v_x - v_o}{100} = 0 \Rightarrow v_o = v_x \left(\frac{2 + 100}{R} \right)$$

$$\Rightarrow \frac{0 - v_i}{100} + \frac{0 - v_x}{R} = 0 \Rightarrow v_x = -\frac{R}{100} v_i,$$

$$\frac{v_o}{v_i} = -\frac{R}{100} \left(2 + \frac{100}{R} \right) = -10$$

$$2R + 100 = -1000, R = 450 \text{ k}\Omega$$

$$6. (A) \frac{0 - v_i}{R} + \frac{0 - v_1}{R} = 0, v_1 = -v_i$$

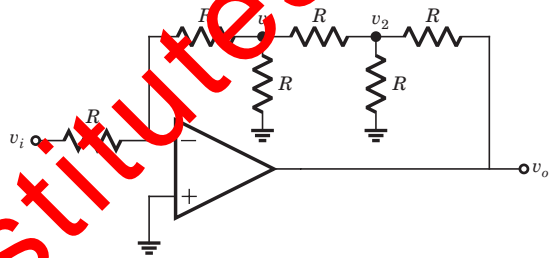

Fig. S3.5.6

$$\frac{v_1 - 0}{R} + \frac{v_1 - v_2}{R} + \frac{v_1}{R} = 0, 3v_1 = v_2, v_2 = -3v_i$$

$$\frac{v_2 - v_1}{R} + \frac{v_2}{R} + \frac{v_2 - v_o}{R} = 0$$

$$-3v_i + v_i - 3v_i - 3v_i = v_o \Rightarrow \frac{v_o}{v_i} = -8$$

$$7. (A) i_1 = \frac{v_i - v_1}{100k}$$

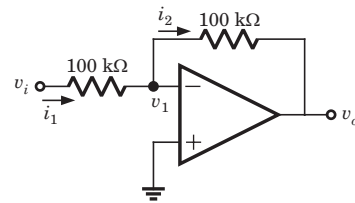

Fig. S3.5.7

$$i_2 = \frac{v_1 - v_o}{100k}, i_1 = i_2, v_1 - v_o = v_i - v_1$$

$$\Rightarrow 2v_1 - v_o = v_i, v_o = -A_{od}v_1$$

$$v_1 = -\frac{v_o}{A_{od}} = \frac{2v_o}{A_{od}} - v_o = v_i$$

$$\frac{v_o}{v_i} = \frac{1}{\left(1 + \frac{2}{A_{od}} \right)} \Rightarrow v_o = -\frac{2}{(1 + 2 \times 10^{-3})} = -1.996$$

8. (B) A closed loop gain $A_{CL} = \frac{v_o}{v_i} = \frac{A_{od}}{1 + A_{od} \beta}$

$$\beta = \frac{2k}{8k + 2k} = 0.2$$

$$A_{CL} = \frac{45}{1 + (45)(0.2)} = 4.5$$

9. (C) $i_1 = \frac{15}{6k} = 0.25 \text{ mA}$, $i_1 = i_2$

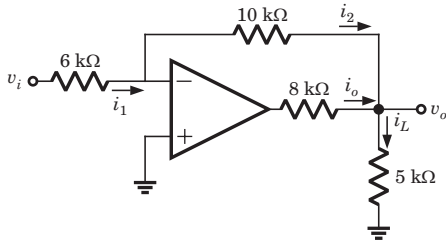

Fig. S3.5.9

$$v_o = -10ki_2 = -2.5 \text{ V}, i_2 + i_o = i_L$$

$$0.25\text{mA} + i_o = -\frac{2.5}{5k}, i_o = -0.75 \text{ mA}$$

10. (B) This is summing amplifier

$$v_o = -80 \left(\frac{0.5}{20} - \frac{1}{40} + \frac{2}{60} \right) = -2.67 \text{ V}$$

11. (B) Output of first op-amp $v_{o1} = -\frac{20}{2} v_{i1}$

$$= -10(1 + 2 \sin \omega t) \text{ mV}$$

The second stage is summing amplifier

$$v_o = -20 \left(\frac{-10(1 + 2 \sin \omega t)}{1} - \frac{10}{1} \right) \text{ mV}$$

$$= 0.4(1 + \sin \omega t) \text{ mV}$$

12. (B) $v_+ = \frac{v_i}{500 + 1}$, $v_- = \frac{A_{od} v_i}{501}$

$$(2.5)(501) = A_{od}(5), v_{o1} = -250.5$$

13. (A) $v_+ = \frac{18 \times 40}{20 + 40} + \frac{15 \times 20}{20 + 40} = 17 \text{ V}$

$$v_o = \left(1 + \frac{100k}{100k} \right) v_+ = 34 \text{ V}$$

14. (C) $\frac{v_+}{30} + \frac{v_+ - 10}{60} + \frac{v_+ - 15}{20} = 0$

$$v_+ = \frac{1}{6} + \frac{3}{4} = \frac{11}{12}$$

$$v_o = v_+ \left(1 + \frac{100}{20} \right) = \frac{11}{12} (1 + 5) = 5.5 \text{ V}$$

15. (A) $v_+ = v_i = v_-$

let v_1 be the node voltage of T network

$$\frac{v_-}{R} + \frac{v_- - v_1}{R} = 0 \Rightarrow v_1 = 2v_- = 2v_i$$

$$\frac{v_1 - v_-}{R} + \frac{v_1}{R} + \frac{v_1 - v_o}{R} = 0 \Rightarrow 3v_1 = v_- + v_o,$$

$$6v_i = v_i + v_o \Rightarrow \frac{v_o}{v_i} = 5$$

16. (A) $v_+ = v_i$, $v_- = v_i = v_o$, $\frac{v_o}{v_i} = 1$

17. (B) $v_+ = v_i$, $v_- = v_o$

$$A_{od}(v_i - v_o) = v_o$$

$$A_{od} = 999$$

$$\frac{v_o}{v_i} = \frac{A_{od}}{1 + A_{od}} = \frac{999}{1 + 999} = 0.999$$

18. (B) At second stage input to both op-amp circuit is same. The upper op-amp circuit is buffer having gain $A_v = 1$. Lower op-amp circuit is inverting amplifier having gain $A_v = -\frac{R}{R} = -1$. Therefore $v_{o1} = -v_{o2}$.

19. (A) $v_+ = \frac{6 \times 6}{48 + 6} = \frac{2}{3} \text{ V}$, $v_o = \left(1 + \frac{10}{10} \right) v_+ = \frac{4}{3} \text{ V}$

20. (A) Applying KVL to loop,

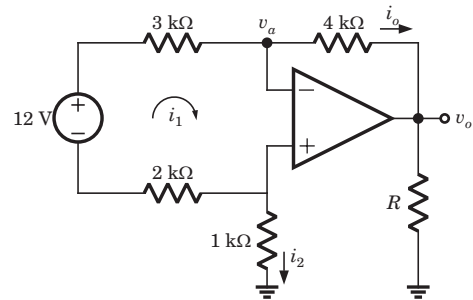

Fig. S3.5.20

$$12 = 3ki_1 + 2ki_1 \Rightarrow i_1 = 2.4 \text{ mA}, i_o = i_1 = 2.4 \text{ mA}$$

$$i_2 = -i_1 = -2.4 \text{ mA}$$

$$v_o = i_2(1k) = -2.4 \text{ V}$$

$$v_o = v_a - i_o(4k) = -2.4 - (2.4)(4) = -12 \text{ V}$$

21. (A) $v_1 = \frac{v_o(4)}{4 + 8} + \frac{12(8)}{4 + 8}$, $v_+ = -2 \text{ V}$, $v_+ = v_-$

$$\frac{v_o}{3} + 8 = -2, v_o = -30 \text{ V}$$

22. (A) $v_+ = 5 \text{ V} = v_-$, $\frac{v_+ - v_o}{10\text{k}} = 0.1 \text{ mA}$

$v_+ - v_o = 1$, $5 - v_o = 1$, $v_o = 4 \text{ V}$

23. (D) $v_+ = v_- = 0$, $i_1 = \frac{12}{4\text{k}} = 3 \text{ mA}$

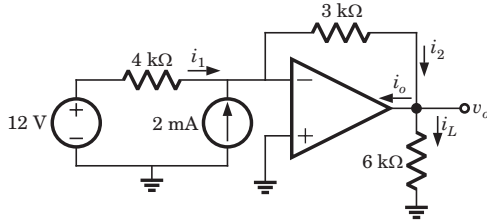

Fig. S3.5.23

$i_2 = 3 + 2 = 5 \text{ mA}$, $v_o = -(5)(3) = -15 \text{ V}$

$i_2 = i_o + i_L$, $5 = i_o + \frac{-15}{6}$, $i_o = 7.5 \text{ mA}$

24. (B) $v_+ = 2.5 \text{ V} = v_-$, $\frac{v_o(4)}{8 + 4} = 2.5 \Rightarrow v_o = 7.5 \text{ V}$

25. (C) $v_{1+} = v_1 = v_{1-}$, $v_{2+} = v_2 = v_{2-}$

Current through 2 kΩ resistor

$i = \frac{v_1 - v_{2-}}{2\text{k}} = \frac{v_1 - v_2}{2\text{k}}$

$v_o = i(6\text{k} + 2\text{k} + 4\text{k}) = \frac{(v_1 - v_2)}{2\text{k}} (12\text{k})$

$\frac{v_o}{v_1 - v_2} = 6 = A_{vd}$

26. (C) $v_{2+} = v_{2-} = 0 \text{ V}$, current through 6 V source

$i = \frac{6}{3\text{k}} = 2 \text{ mA}$, $v_o = -2\text{m}(3\text{k} + 2\text{k}) = -10 \text{ V}$

27. (D) $v_+ = \frac{v_o(1)}{1 + 3} = \frac{v_o}{4}$, $v_- = \frac{v_i(2)}{1 + 1} + \frac{v_o(1)}{2 + 1}$

$v_+ = v_-$, $\frac{v_o}{4} = \frac{v_o}{3} + \frac{2v_i}{5} - \frac{v_o}{3}$, $\frac{v_o}{4} = \frac{2v_i}{5}$, $\frac{v_o}{v_i} = 8$

28. (B) Since op amp is ideal

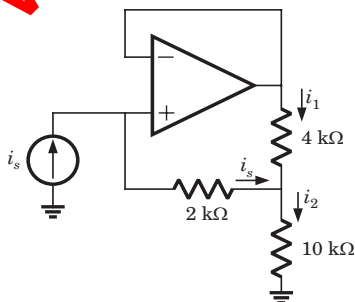

Fig. S3.5.28

$v_- = v_+$, $2ki_s = 4ki_1 \Rightarrow i_s = 2i_1$

$v_s = 2ki_s + 10ki_2$

$i_2 = i_s + i_1$, $v_s = 2ki_s + 10k(i_s + i_1)$, $i_1 = \frac{i_s}{2}$

$v_s = 2ki_s + 10k\left(i_s + \frac{i_s}{2}\right) \Rightarrow \frac{v_s}{i_s} = 17\text{k} = R_{in}$

29. (C) Closed loop gain $A = \left| \frac{R_F}{R_1} \right| = \frac{240\text{k}}{10\text{k}} = 24$

The maximum output voltage $v_{om} = 24 \times 0.02 = 0.48 \text{ V}$

$\omega \leq \frac{SR}{v_{om}} = \frac{0.5 / \mu}{0.48} = 1.1 \times 10^6 \text{ rad/s}$

30. (A) The offset due to V_{io} , $v_o = \left(1 + \frac{R_1}{R_2}\right)V_{io}$

$= \left(1 + \frac{500}{5}\right) 4\text{m} = 404 \text{ mV}$

Due to I_{io} , $v_o = R_F I_{io} = (500\text{k})(150\text{n}) = 75 \text{ mV}$

Total offset voltage $v_o = 404 + 75 = 479 \text{ mV}$

31. (A) $6 = \frac{-v_o}{6\text{k}}$, $i_o = -6 + \frac{v_o}{3\text{k}}$

$i_o = -6 + \frac{-6(6\text{k})}{3\text{k}} = -18 \text{ A}$

32. (B) If $v_i > 0$, then $v_o < 0$, D_1 blocks and D_2 conducts

$A_v = -\frac{6\text{k}}{3\text{k}} = -2 \Rightarrow v_o = (-2)(2) = -4 \text{ V}$

33. (D) If $v_i < 0$, then $v_o > 0$, D_2 blocks and D_1 conduct

$A_v = -\frac{3\text{k}}{2\text{k}} = -1.5$, $v_o = (-1.5)(-2) = 3 \text{ V}$

34. (A) Voltage follower $v_o = v_- = v_+$

$v_+(0^+) = 5\text{m}(250 \parallel 1000) = 1 \text{ V}$, $v_+(\infty) = 0$

$\tau = 8\text{m}(1000 + 250) = 10 \text{ s}$

35. (A) $v_c(0^-) = 5 \text{ V} = v_c(0^+) = 5 \text{ V}$

For $t > 0$ the equivalent circuit is shown in fig. S3.5.35

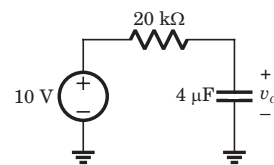

Fig. S3.5.35

$\tau = 20\text{k} \times 4\mu = 0.08 \text{ s}$

$v_c = 10 + (5 - 10)e^{-\frac{t}{0.08}} = 10 - 5e^{-12.5t} \text{ V for } t > 0$

36. (C) $v_- = \frac{(10)(10k)}{10k + 10k} = 5 \text{ V}$

When $v_+ > 5 \text{ V}$, output will be positive and LED will be on. Hence (C) is correct.

37. (B) $v_+ = (2) \frac{R}{2R} = 1 \text{ V}$, $v_- = (2) \frac{R}{2R} = 1 \text{ V}$, $v_d = 0$

$V_{CM} = \frac{v_+ + v_-}{2} = 1$, $v_o = \frac{R_F}{1} \frac{V_{CM}}{CMRR}$

$CMRR = 60 \text{ dB} = 10^3$, $v_o = \frac{100}{1} \frac{1}{10^3} = 100 \text{ mV}$

38. (C) $v_+ = 0 = v_-$,

Let output of analog multiplier be v_p .

$\frac{v_s}{R} = -\frac{v_p}{R} \Rightarrow v_s = -v_p$, $v_p = v_{ss} v_o$

$v_s = -v_{ss} v_o$, $v_o = -\frac{v_s}{v_{ss}}$

39. (B) When $v_i > 2 \text{ V}$, output is positive. When $v_i < 2 \text{ V}$, output is negative.

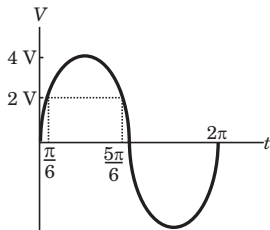

Fig. S3.5.39

Duty cycle = $\frac{T_{ON}}{T} = \frac{\frac{5\pi}{6} - \frac{\pi}{6}}{2\pi} = \frac{1}{3}$

40. (A) $\frac{v_s - v_-}{R_1} = \frac{v_- - v_o}{R_1} \Rightarrow 2v_- = v_s + v_o$

$\frac{v_+}{R_2} + \frac{v_+}{R_L} + \frac{v_+ - v_o}{R_2} = 0 \Rightarrow v_o = \left(2 + \frac{R_2}{R_L}\right) v_+$

$2v_- = v_s + \left(2 + \frac{R_2}{R_L}\right) v_+$, $v_- = v_+$

$\Rightarrow 0 = v_s + \frac{R_2}{R_L} v_+$

$v_+ = -\frac{R_L}{R_2} v_s$, $i_L = \frac{v_+}{R_L}$, $i_L = -\frac{v_s}{R_2}$

41. (D) This is a all pass circuit

$\frac{v_o}{v_i} = H(j\omega) = \frac{1 - j\omega RC}{1 + j\omega RC}$, $|H(j\omega)| = \frac{\sqrt{1 + (\omega R^2 C)^2}}{\sqrt{1 + (\omega RC)^2}} = 1$

Thus when ω and R is changed, the transfer function is unchanged.

42. (B) Let $R_1 = 3 \text{ k}\Omega$, $R_2 = 6 \text{ k}\Omega$, $C = 50 \text{ nF}$

$\frac{v_i}{R_1 \parallel \left(\frac{1}{sC}\right)} + \frac{v_i - v_o}{R_2} = 0 \Rightarrow \left(\frac{v_i}{\frac{R_1}{1 + sR_1 C}}\right) + \frac{v_i}{R_2} = \frac{v_o}{R_2}$

$v_i \left[\frac{R_2}{R_1} (1 + sR_1 C) + 1\right] = v_o$

$\frac{v_i}{R_1} [R_2 + R_1 + sR_1 R_2 C] = v_o$

$\frac{v_o}{v_i} = \frac{R_2 + R_1}{R_1} \left[1 + \frac{sR_1 R_2 C}{R_1 + R_2}\right]$

$\Rightarrow \frac{v_o}{v_i} = \left(1 + \frac{R_2}{R_1}\right) \left(1 + s\left(\frac{R_1 R_2}{R_1 + R_2}\right)C\right)$

$f_{3dB} = \frac{1}{2\pi(R_1 \parallel R_2)C}$

$= \frac{1}{2\pi(3k \parallel 6k)50n} = \frac{1}{2\pi(2k)50n} = 159 \text{ kHz}$

43. (B) The oscillation frequency is

$f = \frac{1}{2\pi\sqrt{6}RC} \Rightarrow 80k = \frac{1}{2\pi\sqrt{6}R(100\pi)}$

$\Rightarrow R = \frac{1}{(80k)(2\pi\sqrt{6})(100\pi)} = 8.12 \text{ k}\Omega$

$\frac{R_F}{R} = 29 \Rightarrow R_F = (8.12k)(29) = 236 \text{ k}\Omega$

44. (A) This is Wien-bridge oscillator. The ratio

$\frac{R_2}{R_1} = \frac{2.1k}{1k} = 2.1$ is greater than 2. So there will be

oscillation

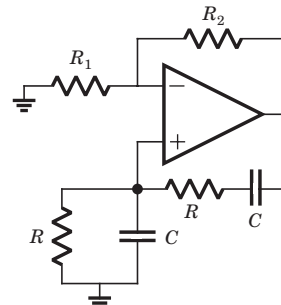

Fig. S3.5.44

Frequency = $\frac{1}{2\pi RC} \Rightarrow 1 \times 10^3 = \frac{1}{2\pi(1k)C}$

$C = \frac{1}{2\pi} \mu\text{F}$

$$45. (C) v_+ = 5 \text{ V} = v_- = v_E,$$

The input current to the op-amp is zero.

$$\begin{aligned} i_{+15V} &= i_Z + i_C = i_Z + \alpha_F i_E \\ &= \frac{15 - 5}{47\text{k}} + \frac{60}{61} \left(\frac{5}{100} \right) = 49.4 \text{ mA} \end{aligned}$$

$$46. (B) v_o = \frac{333}{20} (v_{o1} - v_{o2})$$

$$v_{o1} = -v_{BE1} - V_t \ln \left(\frac{i_{c1}}{i_s} \right), \quad v_{o2} = -v_{BE2} - V_t \ln \left(\frac{i_{c2}}{i_s} \right)$$

$$v_{o1} - v_{o2} = -V_t \ln \left(\frac{i_{c1}}{i_{c2}} \right) = V_t \ln \left(\frac{i_{c2}}{i_{c1}} \right)$$

$$i_{c1} = \frac{v_1}{R_1}, \quad i_{c2} = \frac{v_2}{R_2}$$

$$v_{o1} - v_{o2} = V_t \ln \left(\frac{v_2 R_1}{R_2 v_1} \right), \quad V_t = 0.0259 \text{ V}$$

$$\begin{aligned} v_o &= \frac{333}{20} (v_{o1} - v_{o2}) = \frac{333}{20} (0.0259) \ln \left(\frac{v_2 R_1}{v_1 R_2} \right) \\ &= 0.4329 \ln \left(\frac{v_2 R_1}{v_1 R_2} \right) = 0.4329 (2.3026) \log_{10} \left(\frac{v_2 R_1}{v_1 R_2} \right) \\ &= \log_{10} \left(\frac{v_2 R_1}{v_1 R_2} \right) \end{aligned}$$

$$47. (B) v_+ = v_-, \quad v_Z = \frac{10v_o}{10 + 30} = \frac{v_o}{4}$$

$$v_o = 4v_Z = 6.2 \times 4 = 24.8 \text{ V}$$

www.uniqueinstitutes.org