

6.1

Transfer Functions

1. The equivalent transfer function of three parallel blocks

$$G_1(s) = \frac{1}{s+1}, G_2(s) = \frac{1}{s+4} \text{ and } G_3(s) = \frac{s+3}{s+5} \text{ is}$$

- (A) $\frac{(s^3 + 10s^2 + 34s + 37)}{(s+1)(s+4)(s+5)}$ (B) $\frac{(s+3)}{(s+1)(s+4)(s+5)}$
 (C) $\frac{-(s^3 + 10s^2 + 34s + 37)}{(s+1)(s+4)(s+5)}$ (D) $\frac{-(s+3)}{(s+1)(s+4)(s+5)}$

2. The block having transfer function

$$G_1(s) = \frac{1}{s+2}, G_2(s) = \frac{1}{s+5}, G_3(s) = \frac{s+1}{s+3}$$

are cascaded. The equivalent transfer function is

- (A) $\frac{(s^3 + 10s^2 + 37s^2 + 31)}{(s+2)(s+3)(s+5)}$ (B) $\frac{s+1}{(s+2)(s+3)(s+5)}$
 (C) $\frac{-(s^3 + 10s^2 + 37s^2 + 31)}{(s+2)(s+3)(s+5)}$ (D) $\frac{-(s+1)}{(s+2)(s+3)(s+5)}$

3. For a negative feedback system shown in fig. P.6.1.3

$$G(s) = \frac{s+1}{s(s+2)} \text{ and } H(s) = \frac{s+3}{s+4}$$

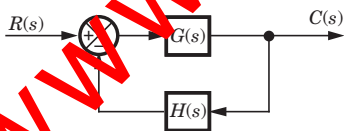

Fig. P.6.1.3

The equivalent transfer function is

- (A) $\frac{s(s+2)(s+3)}{s^3 + 7s^2 + 12s + 3}$ (B) $\frac{s(s+2)(s+3)}{s^3 + 5s^2 + 4s - 3}$
 (C) $\frac{(s+1)(s+4)}{s^3 + 7s^2 + 12s + 3}$ (D) $\frac{(s+1)(s+4)}{s^3 + 5s^2 + 4s - 3}$

4. A feedback control system is shown in fig. P.6.1.4.

The transfer function for this system is

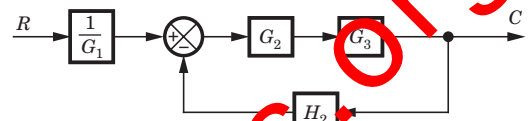

Fig. P.6.1.4

- (A) $\frac{G_1 G_2}{1 + H_1 G_1 G_2 G_3}$ (B) $\frac{G_2 G_3}{G_1(1 + H_1 G_2 G_3)}$
 (C) $\frac{G_2 G_3}{1 + H_1 G_1 G_2 G_3}$ (D) $\frac{G_2 G_3}{G_1(1 + H_1 G_2 G_3)}$

5. Consider the system shown in fig. P.6.1.5.

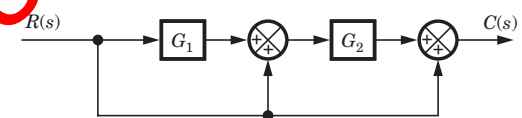

Fig. P.6.1.5

The input output relationship of this system is

- (A) $R(s) \rightarrow [G_1 G_2] \rightarrow C(s)$ (B) $R(s) \rightarrow [1 + G_1 + G_1 G_2] \rightarrow C(s)$
 (C) $R(s) \rightarrow [G_1 + G_2] \rightarrow C(s)$ (D) $R(s) \rightarrow [1 + G_2 + G_1 G_2] \rightarrow C(s)$

6. A feedback control system shown in fig. P.6.1.6 is subjected to noise $N(s)$.

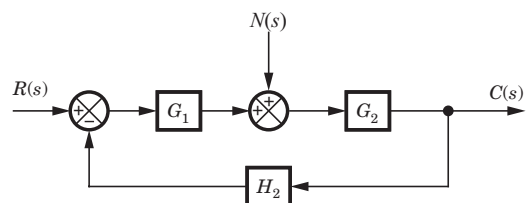

Fig. P.6.1.6

The noise transfer function $\frac{C_N(s)}{N(s)}$ is

- (A) $\frac{G_1 G_2}{1 + G_1 G_2 H}$ (B) $\frac{G_2}{1 + G_1 H}$

- (C) $\frac{G_2}{1 + G_2H}$ (D) None of the above

7. A system is shown in fig. P6.1.7. The transfer function for this system is

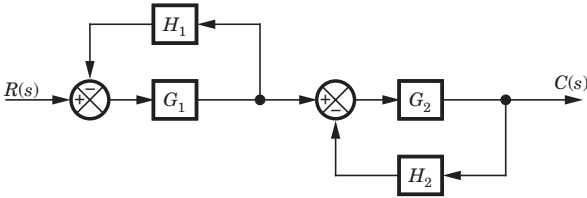

Fig. P.6.1.7

- (A) $\frac{G_1G_2}{1 + G_1G_1H_2 + G_2H_1}$
 (B) $\frac{G_1G_2}{1 + G_1G_2 + H_1H_2}$
 (C) $\frac{G_1G_2}{1 - G_1H_1 - G_2H_2 + G_1G_2H_1H_2}$
 (D) $\frac{G_1G_2}{1 + G_1H_1 + G_2H_2 + G_1G_2H_1H_2}$

8. The closed loop gain of the system shown in fig. P6.1.8 is

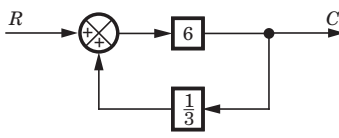

Fig.P6.1.8

- (A) -2 (B) 6
 (C) -6 (D) 2

9. The block diagrams shown in fig. P.6.1.9 are equivalent if G is equal to

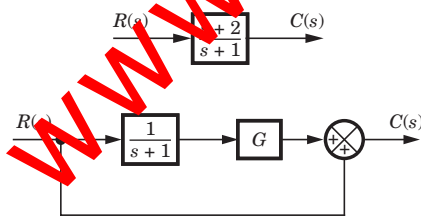

Fig. P.6.1.9

- (A) s + 1 (B) 2
 (C) s + 2 (D) 1

10. Consider the systems shown in fig. P.6.1.10. If the forward path gain is reduced by 10% in each system, then the variation in C₁ and C₂ will be respectively

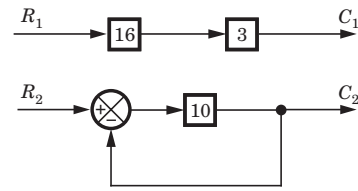

Fig. P.6.1.10

- (A) 10% and 1% (B) 2% and 10%
 (C) 10% and 0% (D) 5% and 1%

11. The transfer function $\frac{C}{R}$ of the system shown in the fig. P.6.1.11 is

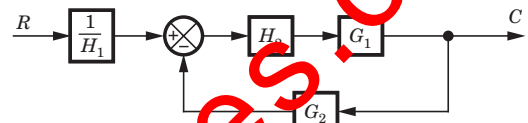

Fig. P.6.1.11

- (A) $\frac{G_1H_2}{H_1(1 + G_2H_2)}$ (B) $\frac{G_1G_2H_2}{H_1(1 + G_1G_2H_2)}$
 (C) $\frac{G_2G_1}{1 + H_2H_2G_1G_2}$ (D) $\frac{G_1G_2}{H_1(1 + G_1G_2H_2)}$

12. In the signal flow graph shown in fig. P6.1.12 the sum of loop gain of non-touching loops is

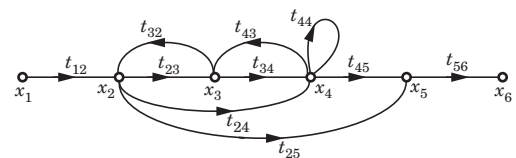

Fig. P.6.1.12

- (A) $t_{32}t_{23} + t_{44}$ (B) $t_{23}t_{32} + t_{34}t_{43}$
 (C) $t_{24}t_{43}t_{32} + t_{44}$ (D) $t_{23}t_{32} + t_{34}t_{43} + t_{44}$

13. For the SFG shown in fig. P.6.1.14 the graph determinant Δ is

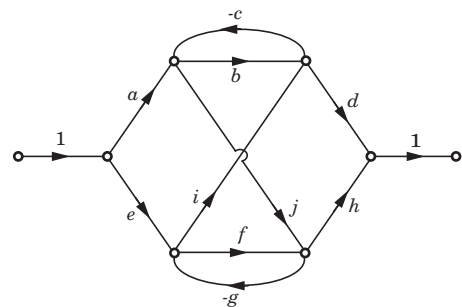

Fig. P.6.1.13

- (A) $1 - bc - fg - bcfg + cigj$
 (B) $1 - bc - fg - cigj + bcfg$

(C) $1 + bc + fg + cigj - bcfg$

(D) $1 + bc + fg + bcfg - cigj$

14. The sum of the gains of the feedback paths in the signal flow graph shown in fig. P.6.1.13 is

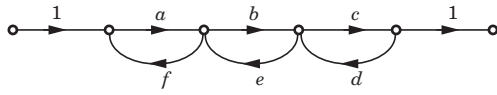

Fig. P.6.1.14

(A) $af + be + cd$

(B) $af + be + cd + abef + bcde$

(C) $af + be + cd + abef + abcdef$

(D) $af + be + cd + cbef + bcde + abcdef$

15. A closed-loop system is shown in fig. P.6.1.15. The noise transfer function $C_n(s)/N(s)$ is approximately

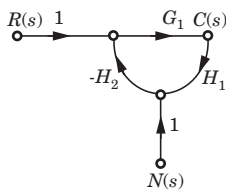

Fig. P.6.1.15

(A) $\frac{1}{G_1(s)H_1(s)}$ For $|G_1(s)H_1(s)H_2(s)| \ll 1$

(B) $\frac{1}{-H_1(s)}$ For $|G_1(s)H_1(s)H_2(s)| \gg 1$

(C) $\frac{1}{H_1(s)H_2(s)}$ For $|G_1(s)H_1(s)H_2(s)| \ll 1$

(D) $\frac{1}{G_1(s)H_1(s)H_2(s)}$ For $|G_1(s)H_1(s)H_2(s)| \ll 1$

16. The overall transfer function $\frac{C}{R}$ of the system shown in fig. P.6.1.16 will be

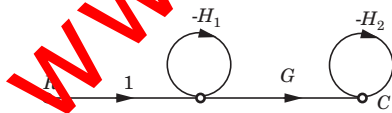

Fig. P.6.1.16

(A) G

(B) $\frac{G}{1 + H_2}$

(C) $\frac{G}{(1 + H_1)(1 + H_2)}$

(D) $\frac{G}{1 + H_1 + H_2}$

17. Consider the signal flow graphs shown in fig. P.6.1.17. The transfer function of the graph

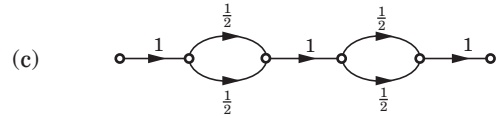
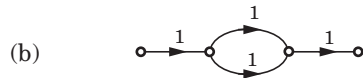

Fig. P.6.1.17

(A) a

(B) b

(C) b and c

(D) a, b and c

18. Consider the List I and List II

List I

List II

(Signal Flow Graph)

(Transfer Function)



1. $a + b$



2. ab



3. $\frac{a}{(1 - ab)}$

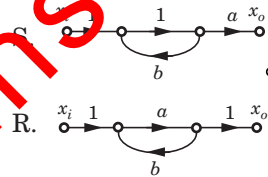

4. $\frac{a}{1 - b}$

The correct match is

	P	Q	R	S
(A)	2	1	3	4
(B)	2	1	4	3
(C)	1	2	4	3
(D)	1	2	3	4

19. For the signal flow graph shown in fig. P.6.1.19 an equivalent graph is

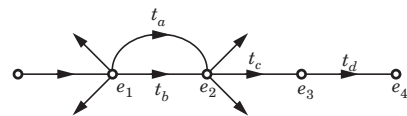
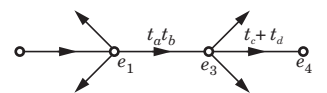
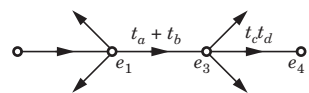
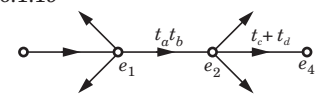
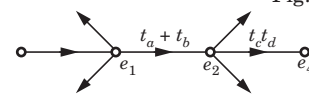

Fig. P.6.1.19



20. Consider the block diagram shown in figure P.6.1.20

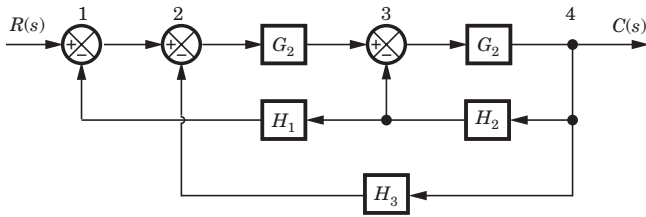
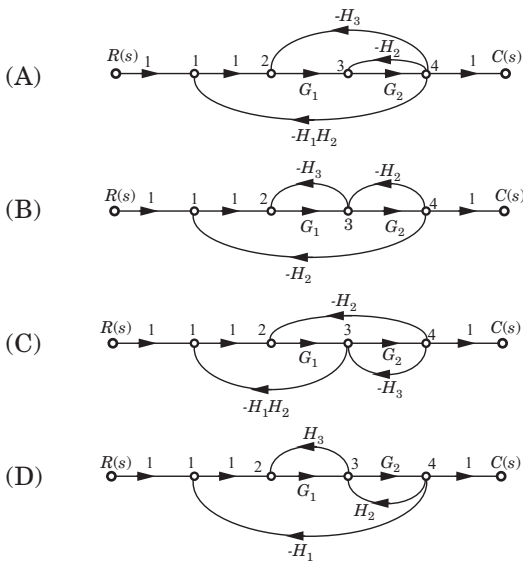

Fig. P.6.1.20

For this system the signal flow graph is



21. The block diagram of a system is shown in fig. P.6.1.21. The closed loop transfer function of this system is

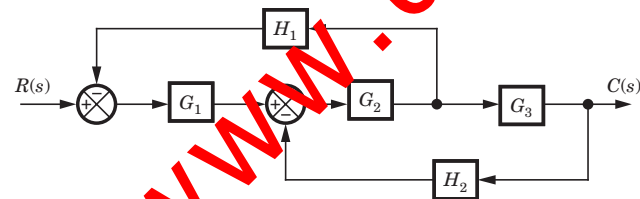

Fig. P.6.1.21

- (A) $\frac{G_1 G_2 G_3}{1 + G_1 G_2 G_3 H_1}$
- (B) $\frac{G_1 G_2 G_3}{1 + G_1 G_2 G_3 H_1 H_2}$
- (C) $\frac{G_1 G_2 G_3}{1 + G_1 G_2 H_1 + G_2 G_3 H_2}$
- (D) $\frac{G_1 G_2 G_3}{1 + G_1 G_2 H_1 + G_1 G_3 H_2 + G_2 G_3 H_1}$

22. For the system shown in fig. P.6.1.22 transfer function $C(s)/R(s)$ is

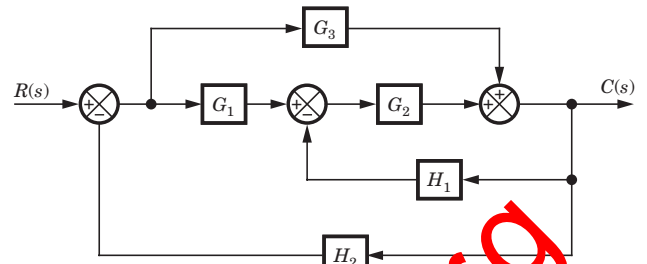

Fig. P.6.1.22

- (A) $\frac{G_3}{1 - H_1 G_2 - H_2 G_3 - G_1 G_2 H_2}$
- (B) $\frac{G_3 + G_1 G_2}{1 + H_1 G_2 + H_2 G_3 + G_1 G_2 H_2}$
- (C) $\frac{G_3}{1 + H_1 G_2 + H_2 G_3 + G_1 G_2 H_2}$
- (D) $\frac{G_3}{1 - H_1 G_2 - H_2 G_3 - G_1 G_2 H_2}$

23. In the signal flow graph shown in fig. P.6.1.23 the transfer function is

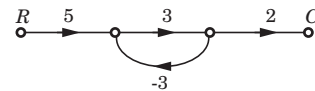

Fig. P.6.1.23

- (A) 3.75
- (B) -3
- (C) 3
- (D) -3.75

24. In the signal flow graph shown in fig. P.6.1.24 the gain C/R is

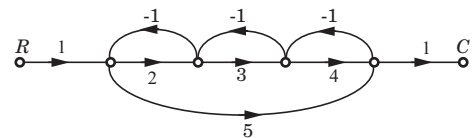

Fig. P.6.1.24

- (A) $\frac{44}{23}$
- (B) $\frac{29}{19}$
- (C) $\frac{44}{19}$
- (D) $\frac{29}{11}$

25. The gain $C(s)/R(s)$ of the signal flow graph shown in fig. P.6.1.25 is

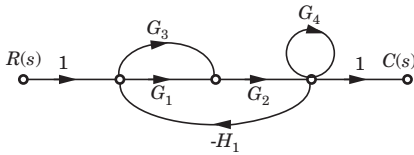

Fig. P.6.1.25

- (A) $\frac{G_1 G_2 + G_2 G_3}{1 + G_1 G_2 H_1 + G_2 G_3 H_1 + G_4}$
- (B) $\frac{G_1 G_2 + G_2 G_3}{1 + G_1 G_3 H_1 + G_2 G_3 H_1 - G_4}$
- (C) $\frac{G_1 G_3 + G_2 G_3}{1 + G_1 G_3 H_1 + G_2 G_3 H_1 - G_4}$
- (D) $\frac{G_1 G_3 + G_2 G_3}{1 + G_1 G_3 H_1 + G_2 G_3 H_1 + G_4}$

26. The transfer function of the system shown in fig. P.6.1.26 is

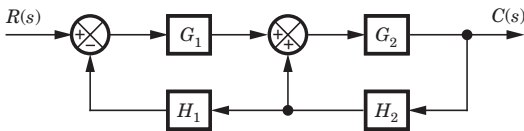

Fig. P.6.1.26

- (A) $\frac{G_1 G_2}{1 - G_1 G_2 H_1 - G_1 G_2 H_2}$
- (B) $\frac{G_1 G_2}{1 - G_2 H_2 - G_1 G_2 H_1}$
- (C) $\frac{G_1 G_2}{1 - G_2 H_2 + G_1 G_2 H_1 H_2}$
- (D) $\frac{G_1 G_2}{1 - G_1 G_2 H_1 H_2}$

27. For the block diagram shown in fig. P.6.1.27 transfer function $C(s)/R(s)$ is

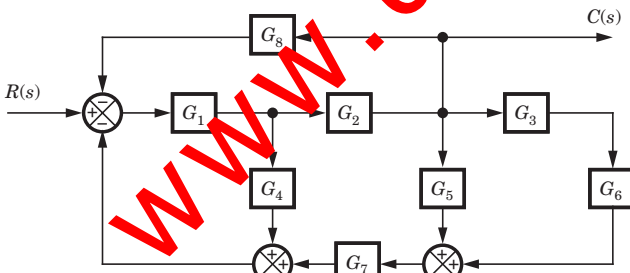

Fig. P.6.1.27

- (A) $\frac{G_1 G_2}{1 + G_1 G_2 + G_1 G_7 G_3 + G_1 G_2 G_8 G_6 + G_1 G_2 G_3 G_7 G_5}$
- (B) $\frac{G_1 G_2}{1 + G_1 G_4 + G_1 G_2 G_8 + G_1 G_2 G_5 G_7 + G_1 G_2 G_3 G_6 G_7}$
- (C) $\frac{G_1 + G_2}{1 + G_1 G_4 + G_1 G_2 G_8 + G_1 G_2 G_5 G_7 + G_1 G_2 G_3 G_6 G_7}$

(D) $\frac{G_1 + G_2}{1 + G_1 G_2 + G_3 G_6 G_7 + G_1 G_3 G_4 G_5 + G_1 G_2 G_3 G_6 G_7 G_8}$

28. For the block diagram shown in fig. P.6.1.28 the numerator of transfer function is

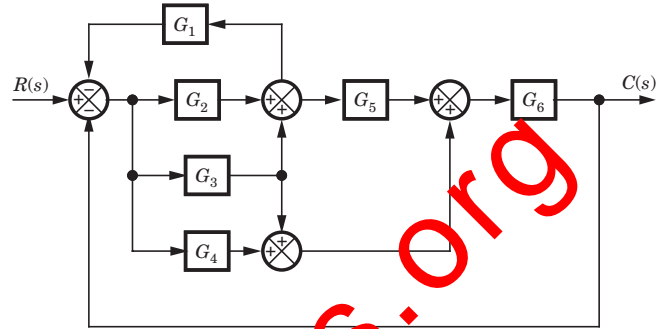

Fig. P.6.1.28

- (A) $G_6[G_4 + G_3 + G_5(G_3 + G_2)]$
- (B) $G_6[G_2 + G_3 + G_5(G_3 + G_4)]$
- (C) $G_6[G_1 + G_2 + G_3(G_4 + G_5)]$
- (D) None of the above

29. For the block diagram shown in fig. P.6.1.29 the transfer function $C(s)/R(s)$ is

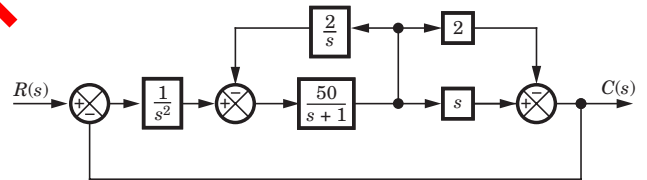

Fig. P.6.1.29

- (A) $\frac{50(s-2)}{s^3 + s^2 + 150s - 100}$
- (B) $\frac{50(s-2)}{s^3 + s^2 + 150s}$
- (C) $\frac{50s}{s^3 + s^2 + 150s - 100}$
- (D) $\frac{50}{s^2 + s + 150}$

30. For the SFG shown in fig. P.6.1.30 the transfer function $\frac{C}{R}$ is

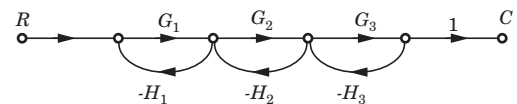

Fig. P.6.1.30

- (A) $\frac{G_1 + G_2 + G_3}{1 + G_1 H_1 + G_2 H_2 + G_3 H_3}$
- (B) $\frac{G_1 + G_2 + G_3}{1 + G_1 H_1 + G_2 H_2 + G_3 H_3 + G_1 G_3 H_1 H_3}$
- (C) $\frac{G_1 G_2 G_3}{1 + G_1 H_1 + G_2 H_2 + G_3 H_3}$

(D)
$$\frac{G_1 G_2 G_3}{1 + G_1 H_1 + G_2 H_2 + G_3 H_3 + G_1 G_3 H_1 H_3}$$

31. Consider the SFG shown in fig. P6.1.31. The Δ for this graph is

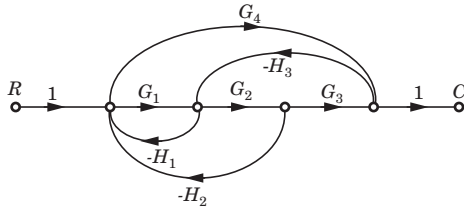

Fig. P.6.1.31

- (A) $1 + G_1 H_1 + G_2 G_3 H_3 + G_1 G_3 H_2$
- (B) $1 + G_1 H_1 - G_2 G_3 H_3 - G_1 G_3 H_3 + G_2 G_4 H_2 H_3$
- (C) $1 + G_1 H_1 + G_2 G_3 H_3 + G_1 G_3 H_3 - G_2 G_4 H_2 H_3$
- (D) $1 + G_1 H_1 + G_2 G_3 H_3 + G_1 G_3 H_3 + G_2 G_4 H_2 H_3$

32. The transfer function of the system shown in fig. P.6.1.32 is

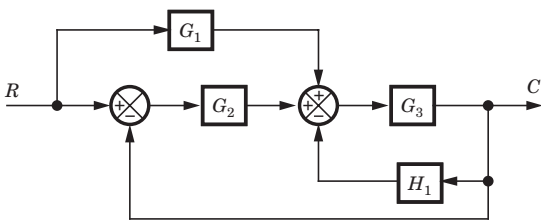

Fig. P.6.1.32

- (A) $\frac{G_2 G_3 + G_1 G_3}{1 - G_3 H_1 + G_2 G_3}$
- (B) $\frac{G_2 G_3 + G_1 G_3}{1 + G_3 H_1 - G_2 G_3}$
- (C) $\frac{G_2 G_3 + G_1 G_3}{1 + G_3 H_1 + G_2 G_3}$
- (D) $\frac{G_2 G_3 + G_1 G_3}{1 - G_3 H_1 - G_2 G_3}$

33. The closed loop transfer function of the system shown in fig. P6.1.33 is

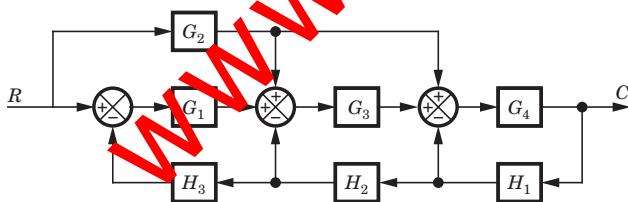

Fig. P.6.1.33

- (A) $\frac{G_1 G_2 G_3 + G_2 G_3 G_4 + G_1 G_4}{1 + G_1 G_3 G_4 H_1 H_2 H_3 + G_2 H_4 H_1 H_2 + G_4 H_1}$
- (B) $\frac{G_2 G_4 + G_1 G_2 G_3}{1 + G_1 G_3 H_1 H_2 H_3 + G_4 H_1 + G_3 G_4 H_1 H_2}$
- (C) $\frac{G_1 G_3 G_4 + G_2 G_4}{1 + G_3 G_4 H_1 H_2 + G_4 H_1 + G_1 G_3 H_3 H_2}$

(D)
$$\frac{G_1 G_3 G_4 + G_2 G_3 G_4 + G_2 G_4}{1 + G_1 G_3 G_4 H_1 H_2 H_3 + G_3 G_4 H_1 H_2 + G_4 H_1}$$

Statement for Q.34-37:

A block diagram of feedback control system is shown in fig. P6.1.34-37

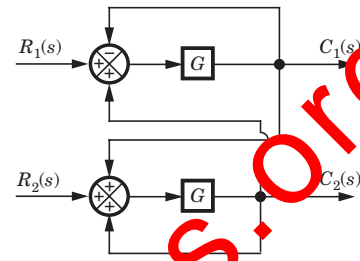

Fig. P.6.1.34-37

34. The transfer function $\frac{C_1}{R_1} \Big|_{R_2=0}$ is

- (A) $\frac{G}{1 - 2G^2}$
- (B) $\frac{G(1 - G)}{1 - 2G^2}$
- (C) $\frac{G(1 - 2G)}{1 - G^2}$
- (D) $\frac{G}{1 - G^2}$

35. The transfer function $\frac{C_1}{R_2} \Big|_{R_1=0}$ is

- (A) $\frac{G}{1 - 2G^2}$
- (B) $\frac{G}{1 - G^2}$
- (C) $\frac{G^2}{1 - 2G^2}$
- (D) $\frac{G^2}{1 - G^2}$

36. The transfer function $\frac{C_2}{R_1} \Big|_{R_2=0}$ is

- (A) $\frac{G(1 + G)}{1 - 2G^2}$
- (B) $\frac{G^2}{1 - 2G^2}$
- (C) $\frac{G^2}{1 - G^2}$
- (D) $\frac{G}{1 - G^2}$

37. The transfer function $\frac{C_2}{R_2} \Big|_{R_1=0}$ is

- (A) $\frac{G(1 + G)}{1 - 2G^2}$
- (B) $\frac{G}{1 - 2G^2}$
- (C) $\frac{G}{1 + G}$
- (D) $\frac{G}{1 - G^2}$

$$\frac{G + s + 1}{s + 1} = \frac{s + 2}{s + 1}$$

Hence $G = 1$

10. (A) In open loop system change will be 10% in C_1 also but in closed loop system change will be less

$$C_2 = \frac{10}{10 + 1} = \frac{10}{11}$$

$$C'_2 = \frac{9}{9 + 1} = \frac{9}{10}, C_2 \text{ is reduced by } 1\%.$$

11. (A) Apply the feedback formula and then multiply by $\frac{1}{H_1}$,

$$\frac{C}{R} = \frac{(H_2 G_1) \left(\frac{1}{H_1} \right)}{1 + H_2 G_1 G_2} = \frac{H_2 G_1}{H_1 (1 + G_1 G_2 H_2)}$$

12. (A) There cannot be common subscript because subscript refers to node number. If subscript is common, that means that node is in both loop.

13. (D) $L_1 = -bc, L_2 = -fg, L_3 = jgic, L_1 L_3 = bcfg$
 $\Delta = 1 - (-bc - fg + cigj) + bcfg = 1 + bc + fg - cigj + bcfg$

14. (A) In this graph there are three feedback loops. $abef$ is not a feedback path because between path x_2 is a summing node.

15. (B) By putting $R(s) = 0$

$$P_1 = -H_2 G_1, L_1 = -G_1 H_2 H_1, \Delta_1 = 1$$

$$T_n(s) = \frac{-H_2 G_1}{1 + G_1 H_2 H_1}$$

$$\text{if } |G_1 H_2 H_1| \gg 1, T_n(s) = \frac{-H_2 G_1}{G_1 H_2 H_1} = \frac{-1}{H_1}$$

16. (C) $P_1 = G, L_1 = -H_1, L_2 = -H_2, L_1 L_2 = H_1 H_2$

$$\Delta_1 = 1$$

$$T(s) = \frac{G}{1 + H_1 + H_2 + H_1 H_2} = \frac{G}{(1 + H_1)(1 + H_2)}$$

17. (B) $G_a = 1, G_b = 1 + 1 = 2, G_c = \frac{1}{4} + \frac{1}{4} + \frac{1}{4} + \frac{1}{4} = 1$

There are no loop in any graph. So option (B) is correct.

18. (B)

$$P. P_1 = ab, \Delta = 1, L = 0, T = ab$$

$$Q. P_1 = a, P_2 = b, \Delta = 1, L = \Delta_k = 0, T = a + b$$

$$R. P_1 = a, L_1 = b, \Delta = 1 - b, \Delta_1 = 1, T = \frac{a}{a - b}$$

$$S. P_1 = a, L_1 = ab, \Delta = 1 - ab, \Delta_1 = 1, T = \frac{a}{1 - ab}$$

19. (A) Between e_1 and e_2 , there are two parallel path. Combining them gives $t_a + t_b$. Between e_2 and e_4 there is a path given by total gain $t_c t_d$. So remove node e_3 and place gain $t_c t_d$ of the branch $e_2 e_4$. Hence option (A) is correct.

20. (A) Option (A) is correct. Best method is to check the signal flow graph. In block diagram there is feedback from 4 to 1 of gain $-H_1 H_2$. The signal flow graph of option (A) has feedback from 4 to 1 of gain $-H_1 H_2$.

21. (C) Consider the block diagram as SFG. There are two feedback loop $-G_1 G_2 H_1$ and $-G_2 G_3 H_2$ and one forward path $G_1 G_2 G_3$. So (D) is correct option.

22. (B) Consider the block diagram as a SFG. Two forward path $G_1 G_2$ and G_3 and three loops $-G_1 G_2 H_2, -G_2 H_1, -G_3 H_2$.

There are no nontouching loop. So (B) is correct.

23. (C) $P_1 = 5 \times 3 \times 2 = 30, \Delta = 1 - (3 \times -3) = 10$

$$\Delta_1 = 1, \frac{C}{R} = \frac{30}{10} = 3$$

24. (A) $P_1 = 2 \times 3 \times 4 = 24, P_2 = 1 \times 5 \times 1 = 5$

$$L_1 = -2, L_2 = -3, L_3 = -4, L_4 = -5,$$

$$L_1 L_3 = 8, \Delta = 1 - (-2 - 3 - 4 - 5) + 8 = 23,$$

$$\Delta_1 = 1, \Delta_2 = 1 - (-3) = 4,$$

$$\frac{C}{R} = \frac{24 + 5 \times 4}{24} = \frac{44}{23}$$

25. (B) $P_1 = G_1 G_2, P_2 = G_3 G_2$

$$L_1 = -G_3 G_2 H_1, L_2 = -G_1 G_2 H_1, L_3 = G_4$$

$$\Delta_1 = \Delta_2 = 1$$

There are no nontouching loop.

$$T(s) = \frac{P_1 \Delta_1 + P_2 \Delta_2}{1 - (L_1 + L_2 + L_3)} = \frac{G_1 G_2 + G_2 G_3}{1 + G_1 G_2 H_1 + G_2 G_3 H_1 - G_4}$$

26. (C) $P_1 = G_1 G_2, L_1 = -G_1 G_2 H_1 H_2, L_2 = G_2 H_2$

$$\frac{C(s)}{R(s)} = \frac{G_1 G_2}{1 + G_1 G_2 H_1 H_2 - G_2 H_2}$$

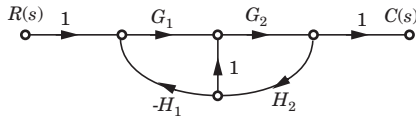

Fig. S6.1.28

27. (B) There is one forward path $G_1 G_2$.
Four loops $-G_1 G_4$, $-G_1 G_2 G_8$, $-G_1 G_2 G_5 G_7$
and $-G_1 G_2 G_3 G_6 G_7$. There is no nontouching loop. So
(B) is correct.

28. (A) SFG:

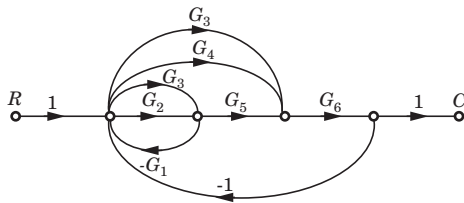

Fig. S6.1.28

$P_1 = G_2 G_5 G_6$, $P_2 = G_3 G_5 G_6$, $P_3 = G_3 G_6$, $P_4 = G_4 G_6$
If any path is deleted, there would not be any loop.
Hence $\Delta_1 = \Delta_2 = \Delta_3 = \Delta_4 = 1$
 $\frac{C}{R} = \frac{G_4 G_6 + G_3 G_6 + G_3 G_5 G_6 + G_2 G_5 G_6}{\Delta}$

29. (A)

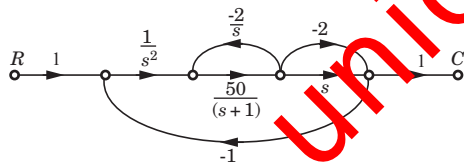

Fig. S6.1.29

$$P_1 = \frac{1}{s^2} \cdot \frac{50}{s+1} \cdot s = \frac{50}{s(s+1)}$$

$$P_2 = \frac{1}{s^2} \cdot \frac{50}{s+1} \cdot (-2) = \frac{-100}{s^2(s+1)}$$

$$L_1 = \frac{50}{s+1} \cdot \frac{-2}{s} = \frac{-100}{s(s+1)}$$

$$L_2 = \frac{1}{s^2} \cdot \frac{50}{s+1} \cdot s \cdot (-1) = \frac{-50}{s(s+1)}$$

$$L_3 = \frac{1}{s^2} \cdot \frac{50}{s+1} \cdot (-2) \cdot (-1) = \frac{100}{s^2(s+1)}$$

$$\Delta = 1 + \frac{100}{s(s+1)} + \frac{50}{s(s+1)} - \frac{100}{s^2(s+1)}$$

$$\Delta_1 = \Delta_2 = 1$$

$$\frac{C}{R} = \frac{P_1 + P_2}{\Delta} = \frac{50(s-2)}{s^3 + s^2 + 150s - 100}$$

30. (D) $P_1 = G_1 G_2 G_3$
 $L_1 = -G_1 H_1$, $L_2 = -G_2 H_2$, $L_3 = -G_3 H_3$
 $L_1 L_3 = G_1 G_3 H_1 H_3$
 $\Delta = 1 - (-G_1 H_1 - G_2 H_2 - G_3 H_3) + G_1 G_3 H_1 H_3$
 $\Delta = 1 + G_1 H_1 + G_2 H_2 + G_3 H_3 + G_1 G_3 H_1 H_3$
 $\Delta_1 = 1$
 $\frac{C}{R} = \frac{G_1 G_2 G_3}{1 + G_1 H_1 + G_2 H_2 + G_3 H_3 + G_1 G_3 H_1 H_3}$

31. (C) $L_1 = -G_1 H_1$, $L_2 = -G_2 G_3 H_3$
 $L_3 = -G_1 G_2 H_2$, $L_4 = G_1 G_4 H_3 H_3$
 $\Delta = 1 - (-G_1 H_1 - G_2 G_3 H_3 - G_1 G_3 H_3 + G_2 G_4 H_2 H_3)$
 $= 1 + G_1 H_1 + G_2 G_3 H_3 + G_1 G_3 H_3 - G_2 G_4 H_2 H_3$

32. (C) $P_1 = G_2 G_3$, $P_2 = G_1 G_3$,
 $L_1 = -G_3 H_1$, $L_2 = -G_2 H_3$, $\Delta_1 = \Delta_2 = 1$,

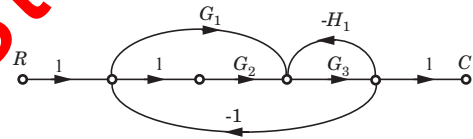

Fig. S6.1.32

$$T(s) = \frac{G_2 G_3 + G_1 G_3}{1 + G_3 H_1 + G_2 G_3}$$

33. (D) $P_1 = G_1 G_3 G_4$, $P_2 = G_2 G_3 G_4$, $P_3 = G_2 G_4$
 $L_1 = -G_1 G_3 G_4 H_1 H_2 H_3$, $L_2 = -G_3 G_4 H_1 H_2$, $L_3 = -G_4 H_1$
There are no non touching loop
 $\Delta_1 = \Delta_2 = \Delta_3 = 1$

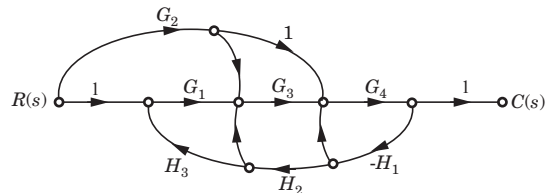

Fig. S6.1.33

$$T(s) = \frac{G_1 G_3 G_4 + G_2 G_3 G_4 + G_2 G_4}{1 + G_1 G_3 G_4 H_1 H_2 H_3 + G_3 G_4 H_1 H_2 + G_4 H_1}$$

34. (B) The SFG of this system is fig. S6.1.34
 $L_1 = -G$, $L_2 = G$, $L_3 = G^2$, $L_1 L_2 = -G^2$
 $\Delta = 1 - (-G + G + G^2) - G^2 = 1 - 2G^2$
From R_1 to C_1 , at $R_2 = 0$,

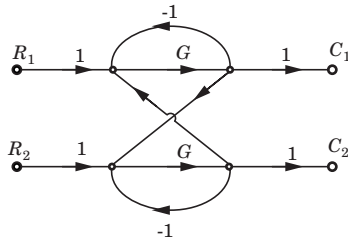

Fig. S6.1.34

$$P_1 = G,$$

$$\Delta_1 = 1 - (G) = 1 - G$$

$$\left. \frac{C_1}{R_1} \right|_{R_2=0} = \frac{G(1-G)}{1-2G^2}$$

35. (C) From R_2 to C_1 at $R_1 = 0$,

$$P_1 = G^2, \Delta_1 = 1,$$

$$\left. \frac{C_1}{R_2} \right|_{R_1=0} = \frac{G^2}{\Delta}$$

36. (B) From R_1 to C_2 ,

$$P_1 = G^2, \Delta_1 = 1,$$

$$\left. \frac{C_2}{R_1} \right|_{R_2=0} = \frac{G^2}{\Delta}$$

37. (A) From R_2 to C_1 at $R_1 = 0$,

$$P_1 = G, \Delta_1 = 1 - (-G) = 1 + G$$

$$\left. \frac{C_2}{R_2} \right|_{R_1=0} = \frac{G(1+G)}{\Delta}$$

38. (C) From Y_1 to Y_2 , $P_1 = 1$

$$\Delta = 1 - (-G_1H_1 - G_2H_2 - G_3G_4H_3 + G_4H_1H_2 - G_1G_2G_3H_3)$$

$$\Rightarrow \Delta = 1 + G_1H_1 + G_2H_2 + G_3G_4H_3 + G_4H_1H_2 - G_1G_2G_3H_3$$

$$\Delta_1 = 1 + G_2H_2, \frac{Y_2}{Y_1} = \frac{P_1 \Delta_1}{\Delta} = \frac{1 + G_2H_2}{\Delta}$$

39. (D) From Y_1 to Y_5 , $P_1 = G_1G_2G_3$, $P_2 = G_4G_3$

$$\Delta_1 = \Delta_2 = 1, \frac{Y_5}{Y_1} = \frac{G_1G_2G_3 + G_4G_3}{\Delta}$$

$$\frac{Y_5}{Y_2} = \frac{Y_5}{Y_1} \cdot \frac{Y_1}{Y_2} = \frac{G_1G_2G_3 + G_4G_3}{1 + G_2H_2}$$

40. (C) Consider block diagram as SFG

$$P_1 = \frac{1}{s} \cdot 2s = 2, P_2 = 2 \cdot 2s = 4s$$

$$L_1 = \frac{1}{s}(-5) = \frac{-5}{s}$$

$$L_2 = \frac{1}{s} \cdot 2s \cdot (-1) = -2$$

$$L_3 = 2 \cdot 2s \cdot (-1) = -4s$$

$$L_4 = 2 \cdot (-5) = -10$$

There are no nontouching loop

$$\Delta = 1 - \left(-\frac{5}{s} - 4s - 2 - 10 \right) = 13 + 4s + \frac{5}{s},$$

$$\Delta_1 = \Delta_2 = 1,$$

$$T(s) = \frac{2 + 4s}{13 + 4s + \frac{5}{s}} = \frac{2s(2s + 1)}{4s^2 + 13s + 5}$$

41. (C) $T(s) = \frac{2s(2s + 1)}{6s^2 + 13s + 5} = \frac{2s(2s + 1)}{(s + 0.5)(s + 1.67)}$

So poles are $-0.5, -1.67$
