

Note : Attempt five questions in all, selecting at least one question from each unit.

UNIT-I

1. (A) Explain the following :

(i) Power factor

2-5

(ii) Ohm's law

2-5

Ans. (i) Power factor : Power factor is defined as the ratio of Resistance to impedance or it may be defined as the ratio of active power to apparant power.

$$\cos \phi = \frac{R}{Z}$$

(ii) Ohm's Law : When physical conditions remains same than the ratio of voltage to current is constant.

$$\frac{V}{I} = R$$

Q. 1. (B) Explain various mathematical representations of vectors.

8

Ans. (i) Polar Method of Representation

$$E = r \angle \theta$$

Where r is the mangnitude and θ is the angle

(ii) Rectangular method of representation

$$E = x + jy$$

Where x is the coordinate on x axis and y is the coordinate on y axis.

(iii) Trigonometric method for representation

$$E = (x \cos \theta + y \sin \theta)$$

(iv) Exponential method for representation

$$= r e^{\pm j\theta}$$

Q. 1. (C) Determine the current I in the network below by loop analysis (Each battery has internal sistance of 1 ohm).

7

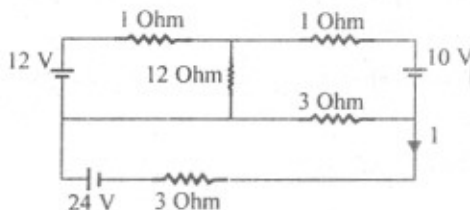

Ans.

$$2I_1 + 12(I_1 - I_2) = 12$$

$$14I_1 - 12I_2 = 12$$

...(i)

$$2I_2 + 3(I_2 - I_3) + 12(I_3 - I_1) = -10$$

$$-12I_1 + 17I_2 - 3I_3 = -10 \quad \dots(ii)$$

$$-3I_2 + 7I_3 = 24 \quad \dots(iii)$$

Applying the Cramer rule and solving the equation, we have

$$I_3 = 4.26 \text{ Amp.}$$

Q. 2. (A) Four circuits A, B, C and D are connected in series across a 240V, 50 Hz supply. The voltages across three of the circuits and their phase angles relative to the current through them are, V_A , 80V at 50° leading V_B , 120V at 65° lagging; V_C , 135V at 80° leading. If the supply voltage leads the current by 15° , find from a vector diagram drawn to scale the voltage V_D across the circuit D and its phase angle.

Ans.

$$V = 240V, 50\text{Hz} = 240 + 80$$

$$V_A = 80 \angle 50^\circ = 51.42 + j 61.2$$

$$V_B = 120 \angle 65^\circ = 50.7 + j 108$$

$$V_C = 135 \angle 80^\circ = 23.4 + j 132.9$$

$$V_D = ?$$

$$\phi = 15^\circ$$

$$V_D = 114.48 - j(182.1)$$

$$= 214 \angle -57.8^\circ$$

Q. 2. (B) Define the following terms :

- (i) RMS and average values
- (ii) Kirchoff's law.

Ans. (i) R.M.S Value : R.M.S value of an alternating quantity is given by that steady (d.c.) current which when flowing through a given circuit for a given time produces the same heat as produced by the alternating current when flowing through the same circuit for the same time.

Average Value : Average value of an alternating current is given by that steady current which transfer across any circuit the same charge as is transferred by that alternating current during the same time.

(ii) Kirchoff Current Law : The algebraic sum of currents meeting at a point is zero.

$$\Sigma I = 0$$

Kirchoff's voltage Law : The algebraic sum of product of current and resistance and voltage in a close loop is equal to zero.

$$\Sigma V + IR = 0$$

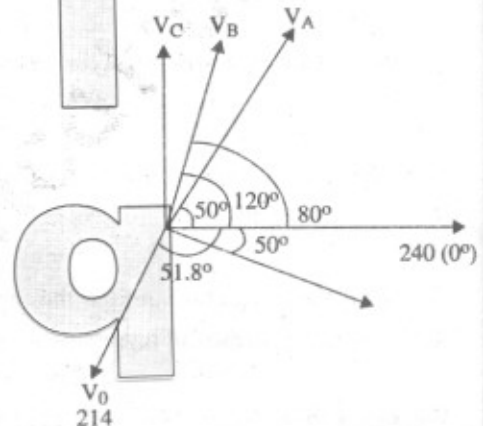
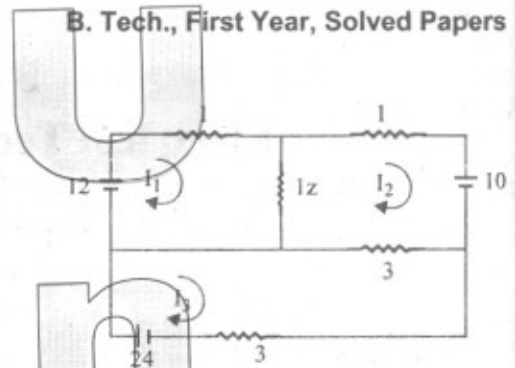

2 1/2

2 1/2

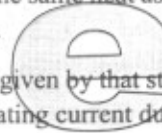

UNIT-II

Q. 3. (A) In the circuit shown below, find the current in branch AB using superposition theorem. 12

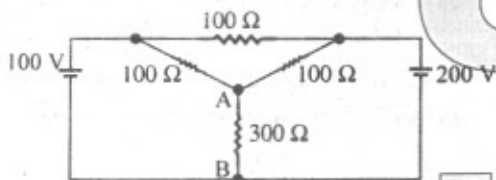

Ans.

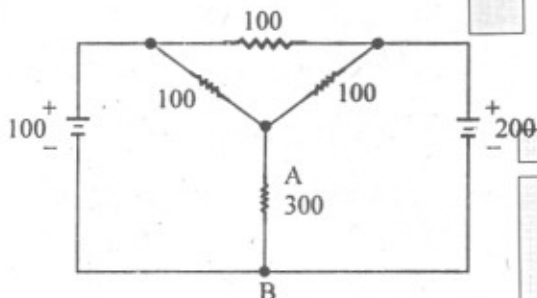

If 100V Source existing

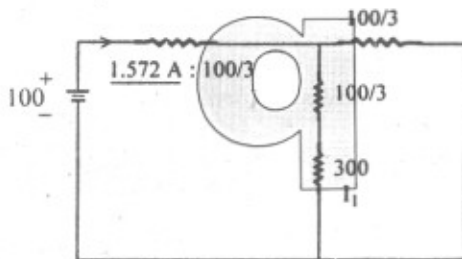
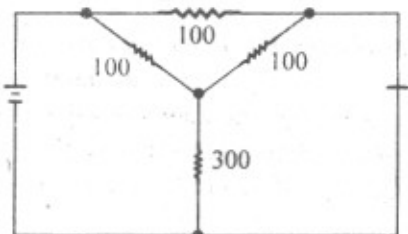

$$I_1 = \frac{1.572 \times 100/3}{\frac{100}{3} + \frac{100}{3} + 300} = 1.74 \text{ MA.}$$

∴ $I_2 = 3.48 \text{ MA.}$

$$I = I_1 + I_2 = 1.74 + 3.48 = 5.22 \text{ MA.}$$

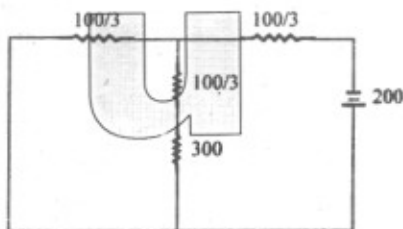

Q. 3. (B) Explain the maximum power transfer theorem along with a suitable example. 8

Ans. Maximum Power Transfer Theorem : Maximum power transfer theorem state that in a D.C. circuit maximum power transfer from source to load when source resistance is equal to load resistance.

$$R_s = R_L$$

The maximum efficiency of M.P.T. is 50%.

Buffer stages are the example of maximum power transfer theorems.

Q. 4. (A) Defines series resonance. Draw reactance curves for individual and total reactance for series RLC circuit. Derive the expression for bandwidth in terms of circuit parameters. 14

Ans. Series Resonance : A series resonance is the condition in RLC series circuit when total reactance of the circuit became equal to zero.

Bandwidth : Let f_1 and f_2 are two cut of frequencies bandwidth is the range of frequency with in which the power dissipated in resistance is greater than or equal to the half of power dissipated at resonance.

$$I = \frac{E}{[R^2 + (X_L - X_C)^2]^{1/2}}$$

$$= \frac{I_m}{[1 + \left(\frac{X_L - X_C}{R}\right)^2]^{1/2}}$$

and current passing at half power points, I_1 and I_2 are given by

$$I_1 = I_2 = \frac{I_m}{\sqrt{2}}$$

Comparing equation, we get

$$X_L - X_C / R = 1$$

and $X_L - X_C = R$

But at resonance $X_L - X_C = 0$

Therefore as X_L increase X_C reduces.

Hence,

$$2\pi f_2 L - 2\pi f_0 L = 0.5 R$$

$$f_2 - f_0 = \frac{R}{4\pi L}$$

$$\therefore f_2 - f_1 = \frac{R}{2\pi L}$$

$$B \cdot w = \frac{R}{2\pi L}$$

Q. 4. (B) A coil having a resistance of 30Ω and an inductance of 0.09 H is connected across a battery of 20 V . Plot the current and its two components. Assume that $t = 0$ when the circuit is completed. 6

Ans. $R = 30 \Omega$, $L = 0.09 \text{ H}$, $V = 20 \text{ V}$

(i) $I_S = V/R = 20/30 = 2/3 \text{ A}$
 $= I_1^2 (V/R) e^{-t/\lambda}$

Total current $I = i_s + i_t$

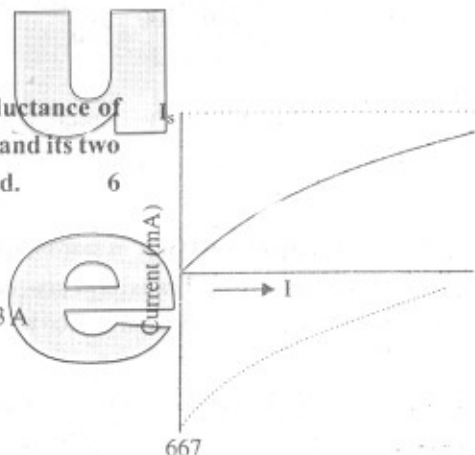
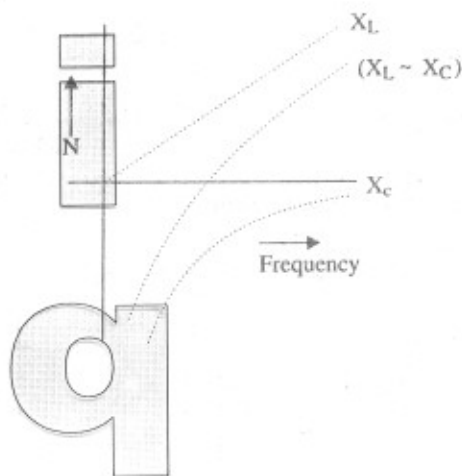

$$\lambda = L/R = 0.09/30 = 3 \text{ millisecond}$$

t	$e^{-t/\lambda}$	i_i	i	t	$e^{-t/\lambda}$	i_i	i
0	1	-667	0	2.5	.435	-290	377
0.5	0.847	-165	102	3	.368	-244	423
1	0.716	-477	190	3.5	0.311	208	459
1.5	0.606	-405	262	4	.264	-176	491
2	0.514	-344	323	4.5	.223	-148	519

UNIT-III

Q. 5. (A) Explain working principle of a single phase transformer. Draw neat sketch of core type transformer showing its various parts. Explain their functions also. 14

Ans. Principle of Transformer : Transformer works on the principle of Faraday's law of electromagnetic induction :

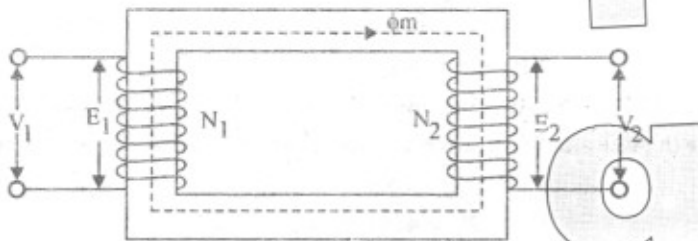

(i) Core : The core is the basic material on which the winding is to be wound. It provides the low reluctance path to the flux.

It can be C, E, L and I shape.

(ii) Winding : Enamelled copper wire is used for the winding of transformer. Winding can be cylindrical or sandwich one mainly in core of the core type transformer. Cylindrical type winding may be used.

Q. 5. (B) Give importance of earthing. 6

Ans. Importance of Earthing :

- It saves the human life from the danger of shock or death by leakage current.
- It saves return path conductor material.
- It protects the large building from atmospheric lightning.
- It maintains the line voltage constant.
- It protects machines fed from overload lines.

Q. 6. (A) Show how power can be measured in balanced three phase star system using two wattmeters. Draw appropriate phasor diagrams. 10

Ans. Fig. shows the circuit diagram of measurement of power by two wattmeter method. The two wattmeters are inserted in any two lines and the potential coil of each is joined to the third line.

Instantaneous current through $W_1 = i_R$

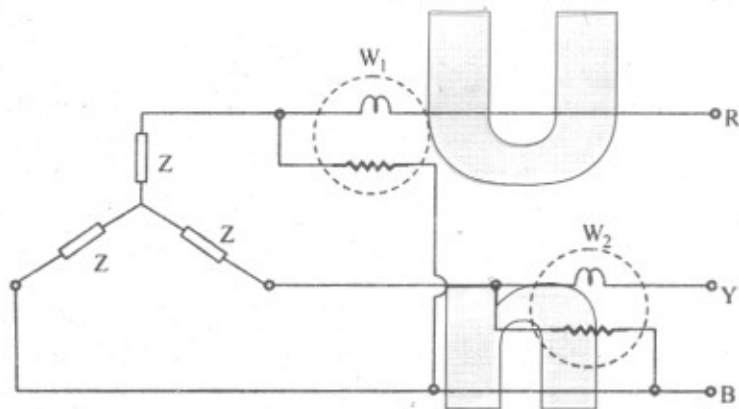

Potential difference across $W_1 = e_R - e_B$

Power load by $W_1 = i_R (e_R - e_B)$

Instantaneous current through $W_2 = i_y$

Potential difference across $W_2 = e_y - e_B$

Power load by $W_2 = i_y (e_y - e_B)$

$$W_1 + W_2 = i_R (e_R - e_B) + i_y (e_y - e_B)$$

$$= i_R e_R + i_y e_y - e_B (i_R + i_y + i_B) = 0$$

$$W_1 + W_2 = i_R e_R + i_y e_y + i_B e_B$$

Q. 6. (B) Three 100Ω resistors are connected in delta and then in star across 415 V , 50 Hz , 3 phase supply. Calculate the line and phase currents in each case and also the power taken from the source. 1

Ans.

$$Z_{ph} = 100 \Omega$$

$$V_L = 415 \text{ V}$$

In star case

$$V_{ph} = \frac{V_L}{\sqrt{3}} = \frac{415}{\sqrt{3}} = 239.6 \text{ V}$$

\therefore

$$I_{ph} = \frac{V_{ph}}{Z_{ph}} = \frac{239.6}{100} = 2.39 \text{ Amp}$$

$$I_L = \sqrt{3} I_{ph} = \sqrt{3} \times 2.39 = 4.15 \text{ Amp}$$

$$\text{Power } P = \sqrt{3} V_L I_L \cos \phi$$

$$= \sqrt{3} \times 415 \times 4.15 \times 1$$

$$= 2982.9 \text{ W}$$

In delta case

$$V_L = V_{ph} = 415 \text{ V}$$

$$I_{ph} = \frac{415}{100} = 4.15 \text{ Amp}$$

$$I_L = \sqrt{3} I_{ph} = 7.18 \text{ Amp}$$

$$P = \sqrt{3} V_L I_L \cos \phi$$

$$= \sqrt{3} \times 415 \times 7.18 \times 1$$

$$= 5160.8 \text{ W}$$

UNIT-IV

Q. 7. (A) Explain working principle of synchronous motor.

13

Ans. Working Principle of Synchronous Motor : When a 3 phase winding is fed by a 3 phase supply, then a magnetic flux of current magnitude but rotating at synchronous speed is produced. Consider a two pole stator of fig.

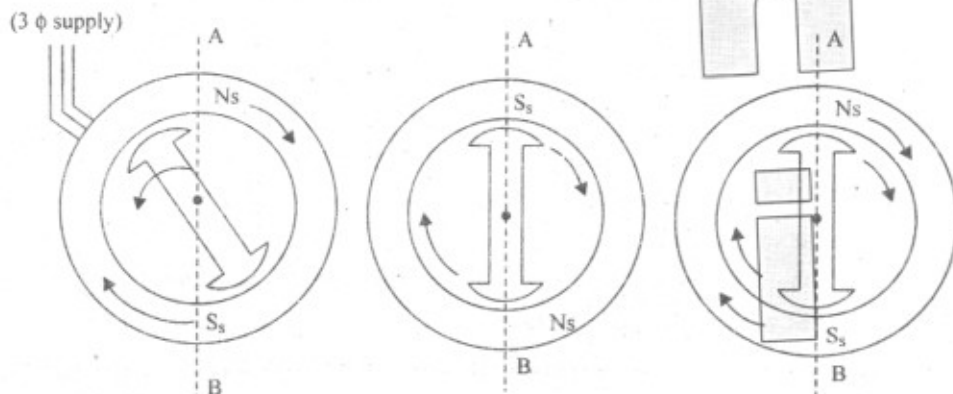

In which are shown two stator pole rotating at a synchronous speed say in clockwise direction with the rotor position as shown, suppose the stator pole are at that instant situated at points A and B. The two similar poles N and N_s as well as S and S_s will repel each other with the result that the rotor tends to rotate in the anticlockwise direction.

But half a period later, stator poles, having rotated around, interchange their position i.e. N_s is at point A and S_s at point B under these conditions, N_s attract S and S_s attract N. Hence rotor tends to rotate clockwise. Hence we find that due to continuous and rapid rotation of stator poles, the rotor is subjected to a torque which is rapidly reversing i.e. quick succession, the stator is subjected to torque which tends to move it in one direction and then in the opposite direction, owing to its large inertia, the rotor cannot instantaneously respond to such quickly reversing torque, with the result that it remains stationary.

Now consider the condition as shown in fig. The stator and rotor poles are attracting each other. Suppose the rotor is not stationary, but is rotating clockwise with such a speed that it turns through one pole pitch by the time the stator pole interchange their position as shown in fig. Here again the stator and rotor pole attract each other. It means that if the rotor pole also shifts their positions along with the stator poles then they will continuously experience a unidirectional torque i.e. clockwise torque.

Q. 7. (B) Draw torque-speed characteristics of 3 phase induction motor with appropriate annotations.

7

Ans. The torque developed by a 3 phase motor depends on its speed but the relation between the two can be represented by a simple equation it is easier to show the relationship in the form of a curve in the form of a graph. T represent the nominal full load torque of the motor. As seen the starting torque (at N = 0) is 1.5 T and the maximum torque (also called breakdown torque) is 2.5 T.

At full load the motor runs at a speed of N. When mechanical load increases, motor speed decreases till the motor torque again becomes equal to load torque.

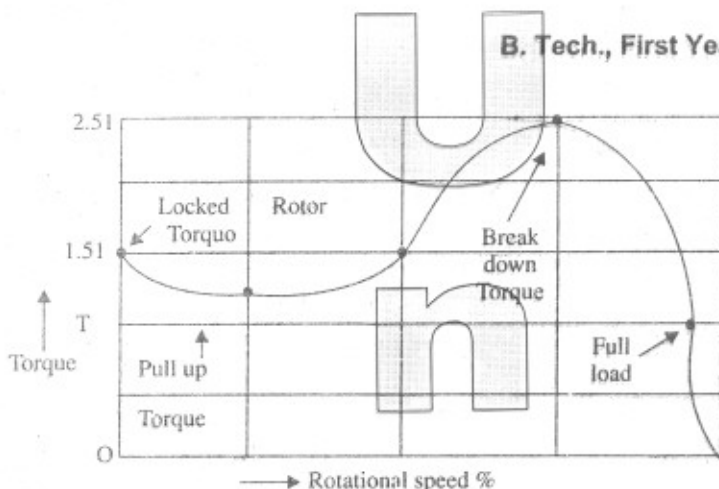

As long as the two torque are in balance, the motor will run at constant speed. However if the load exceed 2.5 T the motor will suddenly stop.

Q. 8. (A) Explain speed control of dc shunt motor and compare methods to achieve it.

Ans. Speed Control of D.C. Shunt Motor :

(i) **Variation of Flux or Flux Control Method:** It is found that $N \propto \frac{1}{\phi}$. By decreasing the flux the

can be increased and vice versa. Hence the name flux or field control method.

(ii) **Armature or Rheostatic Control Method:** This method is used when speed below the n speed are required. As the supply voltage is normally constant, the voltage across the armature is va increasing a variable rheostat or resistance in series with armature circuit.

(iii) **Voltage Control Method :**

(a) Multiple voltage control method

(b) Ward Leonard Method.

Q. 8. (B) Draw the characteristics of DC series and shunt motors with appropriate explanation.

Ans. Characteristic of Series Motor :

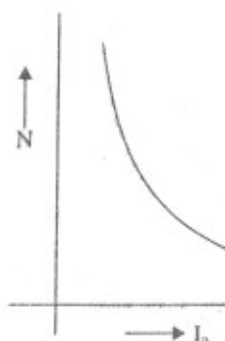
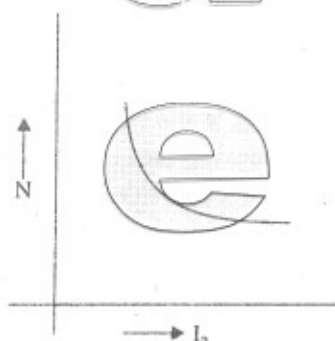
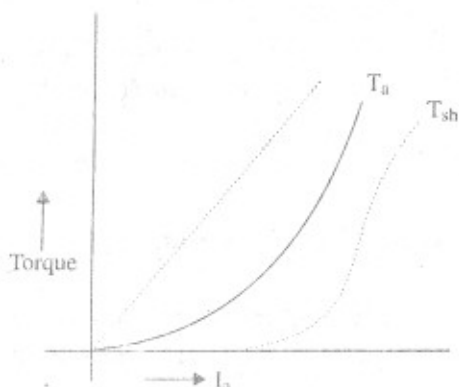

(i) T_a / I_a Characteristic : We have seen that $T_a \propto \phi I_a$, in this case as field winding also carries armature current $\phi \propto I_a$ up to point of magnetic saturation. Hence before saturation $T_a \propto I_a^2$

(ii) N/I_a Characteristic : Variation in the speed can be deduced from the formulae

$$N \propto \frac{E_b}{\phi}$$

(iii) N/I_a or Mechanical Characteristic : It is formed from the above two characteristic that speed may reduce with the increase in torque.

Characteristic of DC Shunt Motor :

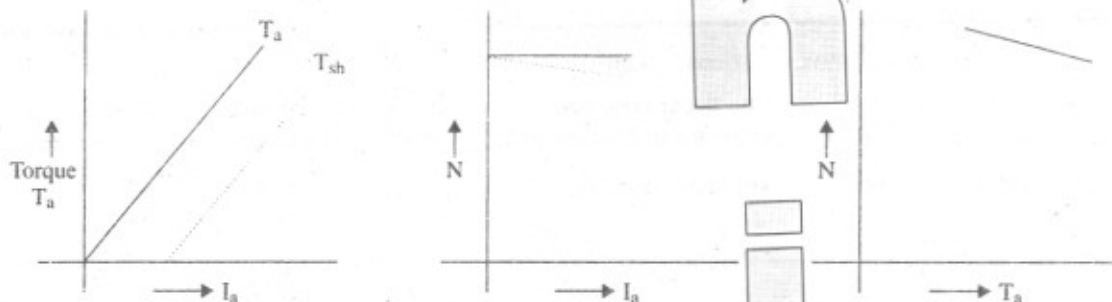

(i) T_a/I_a Characteristic : Assuming the ϕ to be practically constant we find that $T_a \propto I_a$

(ii) N_a/I_a Characteristic : If ϕ is assumed to be constant $N \propto E_b$ is practically constant the speed is for non of purpose constant.

(iii) N/T_a Characteristic : Can be deduced from the above two characteristic.